



FASTCORP

— V E N D I N G —

VERSATILITY THROUGH ROBOTICS

Thank you for purchasing a FASTCORP DIVI merchandiser. This guide will cover safety information and setup of your machine for the first time. Please observe all of the safety precautions at the beginning of this manual. This machine represents over 2 years of product development and incorporates many technological advances offering you years of service without obsolescence.

It is our sincere philosophy that we are partners with our customers and must grow together. With that in mind, we welcome all comments and suggestions either through your sales representative, our customer service department or whomever you have contact with from FASTCORP.

Refer to this manual as you become a DIVI merchandiser in vending.

Thank you,

The FASTCORP Team



The newest version of this manual may be downloaded at <http://www.fastcorp vending.com/support> or scan the QR code.

Table of Contents

<u>SAFETY SYMBOLS, CAUTIONS, AND MEANINGS</u>	3
<u>SAFETY INFORMATION</u>	3
<u>GENERAL MAINTENANCE AND CLEANING</u>	7
<u>WARRANTY</u>	10
<u>FAMILIARIZE YOURSELF WITH THE NEW ROBOT</u>	133
<u>TRANSPORT, UNPACKING, AND INITIAL SETUP INSTRUCTIONS</u>	13
<u>SETUP INSTRUCTIONS</u>	16
<u>FREEZER MAINTENANCE DIVI</u>	18
<u>PRODUCT DISPLAY SYSTEM</u>	21
<u>BIN SETUP/ PLAN-O-GRAM</u>	21
<u>PROGRAMMING</u>	23
<u>APPENDIX</u>	47

SAFETY SYMBOLS, CAUTIONS, AND MEANINGS



Unsafe practices or hazards that may result in severe personal injury or death.



Disconnect power before servicing. Replace all parts and panels before operating. Failure to do so may result in electrical shock or death.



Unsafe practices or hazards that may result in injury or damage.



Caution, risk of fire.



Read and follow directions carefully.



Pressure symbol – to indicate pressure.



Unplug power from wall socket.



Ensure machine is grounded.



Do not disassemble.



Do not touch.



Do Not...



Acceptable / Safe.



Suitable for use in tropical climates.

SAFETY INFORMATION

GENERAL SAFETY CONSIDERATIONS



Before operating the vending machine, please read this manual thoroughly and retain it for your reference. Use this appliance only for its intended purpose as described in this instruction manual. This appliance is not intended for use by children or any person with reduced physical, sensory, mental capabilities, or lack of experience and knowledge, unless they have supervision or instruction concerning use of the appliance by a person responsible for their safety.

These operating instructions cover various models. The specifications of the refrigerator / freezer in your machine may differ slightly from those described in this manual.

R600a, R408, or R134a are optional refrigerants used inside the refrigerator in this machine. Check the label on the freezer to verify which refrigerant is used.



- **This product's refrigerator may contain isobutane (R600a) or other flammable refrigerants. These are flammable and potentially explosive gases.**
- **The thermal insulation foam in the freezer may contain flammable insulation blowing gases. Any exposed foam may be highly flammable and must be carefully treated before disposal.**



Proper disposal requires refrigerants to be safely removed and insulated areas that used flammable blowing gas to be treated properly before disposal. Contact your local authority in regard to proper and safe disposal of the freezer in this product.



- **This machine may be used outdoors.**



- **Climatic zone class T** (Suitable for use in **T**ropical locations, for use in ambient temps of +16 to +43°C.) **Fastcorp highly recommends outdoor installation in a protected location.**

When disposing of the refrigerator and/or machine, remove the door(s), door seal(s), lock(s), and door latch(es) so that children or animals cannot become trapped inside. Contact your local authority to dispose of properly. Children are not allowed to operate, clean, or play in, on, or around the machine.

- Failure to comply could result in injury, suffocation, and death.

All repairs must be performed in accordance with Fastcorp Service Instructions, local codes, and approved safety procedures. Persons attempting to service the machine without proper training or instruction from a Fastcorp service technician may become subject to hazards such as electrical shock which may cause serious injury and death.

Only factory approved Fastcorp parts should be used in the repair of Fastcorp machines.

No repairs, adjustments, or assembly should be undertaken without using appropriate parts, tools, methods, and instructions.



Always remain clear of the robot arm, freezer lid lift mechanism, and cabinet interior when machine power is on and the cabinet door is open.



Your Fastcorp Divi machine must be installed in accordance with this manual as well as state and local codes before use.

IMPORTANT SAFETY WARNINGS



- Do not move the vendor with a hand truck or stair climber (due to the large size and weight of the vendor.) The vendor should be moved with a pallet jack, fork lift truck, or vending machine dolly only.
- Do not use this machine indoors at temperatures above 107.6°F (42°C) or below 28.4°F (-2°C.)
- Do not use this machine outdoors at temperatures above 107.6°F (42°C) or below -34.6°F (-33°C.)
- Do not use this machine at elevations over 6560 feet (2,000 meters.)
- Do not install machine where it will get sprayed with water from surroundings (next to water rides, sea, waterway, car wash, etc.)
- Do not pressure wash or use water jets on or inside machine.
- Do not install in an area with power washers or water jets nearby.
- Do not allow persons with reduced: physical, sensory, mental capabilities, experience, and / or knowledge to operate or clean this machine unless they have supervision or instruction concerning use of the appliance by a person responsible for their safety.
- Do not allow children of any age to use or play with an open machine.
- Do not allow children of any age to operate, fill, maintain, service, or clean this machine.
- Do not allow unsupervised children near this open machine.
- Do not expose machine to heat from radiators or heaters.
- Do not obstruct airflow to ventilation openings of the machine. 3" is the minimum allowed spacing between the back of the machine and any object to allow airflow in and out of the machine. If built in / recessed into a wall, Airflow into the build-in must not be obstructed (top and bottom.) A build in / built in structure must allow unobstructed airflow in the bottom and out the top.
- Do not install / set machine out of level. The vendor must be located on a solid, flat and level surface. Machine must be level within 2° and must have all 4 feet touching solid ground.
- If the machine will be subject to misuse or vandalism, it is recommended that the vendor be secured to the floor or wall to minimize injury or death from tipping.
- Do not install machine in an area with a weak floor. Machine install location floor must be capable of supporting the weight / load of a fully stocked machine.
- Do not attempt to repair, disassemble, or modify the machine unless you have had training.
- Do not recharge the refrigerator / freezer except by a certified and appropriately licensed HVAC tech.
- Do not recharge the refrigerator / freezer with refrigerant other than that shown on the freezer label.
- In order to reduce flammability hazards, do not remove or install the freezer unless you are a suitably qualified person to do so.
- Do not damage the refrigeration circuit. In case of damage to the refrigeration circuit, ventilate the area by opening windows. Do not operate any equipment that may produce sparks or flame in the area.
- Do not touch the inside of the freezer with wet hands.
- Do not store explosive or flammable substances such as aerosols cans with a flammable propellant inside.
- Do not store volatile or flammable materials in this machine as they may explode.
- Do not freeze carbonated drinks. They may explode.
- Do not consume food if it is too cold. Food removed from the freezer may be cold enough to cause damage to bare skin.
- Do not use aerosols near this machine.
- Do not install this machine where gas may leak.
- Do not touch the vacuum box until it is allowed to cool. Vacuum box will become hot from use.



Failure to comply with the above warnings and hazards could result in electrical shock, injury, fire, burns, explosion, and death.



- A-weighted acoustical noise emitted by this appliance has a sound pressure level (SPL) below 70dB.

A. SANITATION & FOOD SAFETY REQUIREMENTS



- Access to the service and filling areas are permitted only to competent adult persons having knowledge and practical experience in vending machine sanitation best practices for safety and hygiene.
- Cold foods must be maintained at 41°F (5°C) or below.
- The food manufacturer may have a specific upper temp limit below 41°F (5°C) that the food must be kept below to maintain product integrity. Check with the food manufacturer for their specific upper temp limits.
- Do not fill machine with or vend any food products except for properly sealed, unopened, and pre-packaged food items. Sell by dates must be observed along with appropriate state and local laws. Past date food items must be disposed of properly.
- Potentially hazardous, ready to eat foods held for more than 24 hours must be labeled with the food preparation date to indicate the date by when the food shall be consumed by. This must be seven days or less from the day of preparation. Dispose of ready-to-eat potentially hazardous foods if not consumed within seven days from the date of preparation. Foods which had been prepared in a food processing plant are exempt. If not consumed in time the food must be discarded.
- All food must be labeled in accordance with the Code of Federal Regulations, Title 21.
- All potentially hazardous food must be vended in the original container in which it was packaged at the preparation facility.
- Prepackaged foods that have damaged or non-airtight packaging must be discarded.
- The machine must be checked for food spills and cleaned when found every time it is serviced or filled.
- Food spills must be cleaned up promptly, thoroughly, and properly to avoid sanitation issues.
- Food / product must be inspected for spoilage after a power failure and if a [health sensor active](#) code is present. The machine will automatically go out of service with a health error if freezer temp has risen above potentially unsafe limits to prevent vending spoiled foods. Food in a freezer that suffered a prolonged power failure may become spoiled and dangerous to eat. Spoiled food should be disposed of properly and not consumed.

B. ELECTRICAL / POWER SAFETY AND REQUIREMENTS

Warning - Electric Shock Hazard



WORKING ON AN ENERGIZED ELECTRICAL CIRCUIT COULD CAUSE SHOCK, BURN, SERIOUS HARM, OR DEATH! ALWAYS POWER OFF AND UNPLUG THE DIVI VENDOR BEFORE ATTEMPTING TO MAKE REPAIRS, TO ADJUST, OR INSTALL PARTS ON / IN THE MACHINE.

The cabinet serial plate indicates the proper Voltage and Amperage required for the vendor.

DIVI MODEL	USAGE	VOLTAGE	Frequency (Hz)	AMPERAGE
FC01/FC03/FC05/FC07	DOMESTIC - N.A.	110-120	60	12
FC02/FC04/FC06/FC08	INTERNATIONAL	220-240	50	8

The vendor must be plugged into a properly rated, single phase, grounded, AC (alternating current) outlet equipped with its own circuit protection (fuse/circuit breaker).



- Do not touch any power cords, switches, fuses, circuit breakers, etc. with wet hands.
- Do not plug in several machines into the wall outlet. This machine should only be plugged into its own outlet which supplies a voltage and amperage rating listed on the machine's power rating label. Wall outlet must be in good mechanical and electrical order and must be maintained to local electrical codes. If the outlet is loose or damaged, do not plug machine in - there is a risk of fire or electrical shock.
- Do not bend the power cord excessively.
- Do not tie, twist, bury, pinch, crush, wedge, entrap, or enclose the power cord.
- Do not place heavy objects on top of power cord.
- Do not hang the power cord over sharp objects.
- Do not use an extension cord with this machine. The vendor must be positioned close enough to an electrical outlet so that an extension cord is not necessary.

- Do not plug machine into a power strip, extension cord, or power splitter. Machine must be plugged directly into an appropriate wall outlet.
- Power cord should extend out or down out of wall outlet to prevent wire strain. If wire extends up from wall outlet an electrician must be called in to flip the wall plug to prevent cord strain and failure.
- Do not crush the power cord when moving the machine.
- Do not unplug machine by pulling on the power cord. It must be unplugged by gripping the plug and pulling.
- Do not use electrical appliances inside the food storage compartments of this machine.
- Do not replace fuses with any other than the standard fuse. Reference the fuse table in this manual or the fuse table in your machine.



Failure to comply with electrical / power safety warnings and requirements above could result in a damaged power cord. A damaged cord could cause electrical shock, fire, fire hazard, and death. Do not plug in machine if the power cord is showing signs of wear, cracks, abrasion, crush, or pinch damage. Damaged cords must be replaced. Contact Fastcorp to order a replacement cord.



C. GROUND THE VENDOR

The DIVI Vendor MUST be properly grounded. It must be plugged into a properly grounded outlet that complies with state and local codes. If the outlet will not accept the power cord plug, contact an electrician to install an appropriate AC outlet and line if necessary that meets local codes.

- Never use gas pipes, plastic water pipe, telephone lines, or other inappropriate connections as a grounding source.
- The machine must be properly grounded to prevent any power leakages or electrical shocks caused by current leakage from the machine.



- Do not remove the ground pin or in any way bypass, modify, defeat, or destroy the grounding system of the vendor.
- Do not bypass, defeat, destroy, or replace the power cord with a non GFCI cord if the machine was originally equipped with a GFCI (ground fault circuit interrupter) cord (all 110v Divi machines.)
 - Failure to comply with proper grounding listed above may result in shock, electrocution, burn, explosion, and death.

D. General Maintenance

Lubrication

With the exception of the robot hose drive bearings, do not use oil or any other lubricants on moving parts. Lubricants may damage the mechanical and electronic components. 3 in 1 oil may be used very sparingly on hose drive bearings. These do not require oil but occasionally can squeak. 3 in 1 oil will stop the squeak. WD40 and other spray oils **are not to be used** on components in this machine.

E. Cleaning Considerations and Requirements

- It is important to maintain the machine in accordance with this manual. The cabinet, freezer, door, and delivery bin should be periodically wiped down with a non-abrasive damp cloth and vacuumed as necessary.
- Children and persons with reduced physical, sensory, mental capabilities, experience, and / or knowledge should not clean or maintain this machine unless they have supervision or instruction concerning use of the appliance by a person responsible for their safety.

- Many commercially available cleaning and antibacterial products may contain solvents that may attack the plastic and rubber components in this machine.
- To allow for proper air flow, the fan located in the lower rear corner(s) of the cabinet should be cleaned using a cloth or a vacuum at regularly scheduled intervals. Those intervals will be dictated by the dustiness of the location. All machines should be cleaned at least once a month.
- [Manual freezer defrosting](#) should be done as needed using only the included ice scraper. Do not use mechanical devices or other means to accelerate defrosting other than the included ice scraper. Failure to comply could result in freezer damage, fire, explosion, and death.



- Disconnect power prior to servicing any electrical or moving components including the fan. Do not pull on wires that supply power to any components. Failure to comply may result in damage to the vendor and increased risk of electric shock.
- To avoid the possibility of a fire hazard and to decrease the possibility of restricted airflow into the vendor, do not store anything or allow debris to accumulate on the bottom of the door, inside or behind the cabinet, near the fan or in the general area of the vendor.
- Do not use water, soap or any other liquid to clean the inside of the vendor. The outside of the cabinet and glass can be cleaned using a soft cloth and a mild detergent. Never use flammable materials to clean any part of the vendor.
- Do not pressure wash or use water jets to clean machine.
- Do not immerse machine in water ever!
- If the inside of the machine gets wet, or machine is immersed, power must be disconnected to the machine and allowed to dry completely before restoring power to machine and restoring machine into operation.



Do not go near or attempt to unplug an already immersed machine. Power should be disconnected at the breaker box or other disconnect switch if the area is dry. If it is an emergency, call the fire department to cut the power.



If you are unsure of the above requirements, please call Fastcorp Service at (888) 441-3278 for assistance.

F. Machine Dimensions:

HEIGHT	72.5 - INCHES / 185 CENTIMETERS
WIDTH	41 - INCHES / 104 CENTIMETERS
DEPTH	37 - INCHES / 91 CENTIMETERS(WITHOUT BACK BRACE)
WEIGHT, NET	775 - POUNDS / 352 KILOGRAMS
WEIGHT, GROSS	800 - POUNDS / 363 KILOGRAMS
Machine Model Numbers:	
FC01=DIVI basic	
FC02=DIVI Basic 220VAC	
FC03= DIVI Refrigerated	
FC04= DIVI Refrigerated 220VAC	
FC05= DIVI Ambient	
FC06= DIVI Ambient 220VAC	
FC07= DIVI Combo (Refrigerated & Ambient)	
FC08= DIVI Combo (Refrigerated & Ambient) 220VAC	



Note: Vendor door can be opened and machine carefully “clamshelled” through a 36” door opening.

Quick Start Guide for Fastcorp LLC Vendor

- Unwrap and inspect your machine for any shipping damage.
- Use a pair of Channel Locks or wrench to adjust the 4 leveling legs until machine is level. A bubble level has been supplied with the machine. An out of level machine can cause bin locations to be off as well as prevent the cooling system from operating properly.
- Remove all shipping tie-wraps. Ensure robot is free to move and freezer lid opens.
- If you are adding currency systems to the machine install them at this time with the machine powered OFF.
- **Hot plugging currency systems can destroy the control board!** Be sure to switch off machine power before plugging in any MDB / currency handling devices.
- Undo cord from back of machine and plug into 15A or 20A dedicated wall outlet.
- The main power switch is located behind or to the left of the freezer – switch to ON.
- The controller power switch is under and to the left the delivery bin – switch it on at this time.
- The machine display is mounted on a hinged plate. Pull it from inside the door to view from inside the cabinet where the keypads are located.
- When the machine powers up you should see menu #1 “Change Price”. The machine is in service mode when you see the menu options. It is in vend mode if it says please insert money or out of service. If the machine is in vend mode with the door open and you need service mode, push the door switch in (behind the T handle.) The door switch is a 3 position switch. Pushed in (door closed - momentary) is vend mode. Switch in the middle position is service mode. The switch can also be pulled out to force vend mode for testing.
- Press the “VAC” button to unlock service mode access.
- Use the * key to scroll to menu #7 and verify your time and date.
- Scroll to menu #13 and verify your health sensor is set correctly for your product.
- If your machine was pre-Programmed from the factory you should scroll to menu #22 “Verify All Bins” This menu option will move the robot to each programmed location. If you see the location needs adjustment move the robot by hand into position and then press # to save and it will automatically go to next selection until you see “Selection Not Found.” If bin to robot alignment is consistently off, check the machine for level and adjust if necessary before adjusting bins. Also check vacuum hose for straightness.
- The vacuum hose can set a memory from sitting for a long time. To help straighten the vacuum hose go to menu 20 and press the down button until the picker tip (the pickup head) is down near the bottom of the machine. Push the robot to the side where it won't get crushed in anything and let the machine sit overnight.
- If your machine is not pre-programmed you should use menu #4 “Create Selection” to start programming. See “Bin programming / Plan-o-gram” for instructions.
- Free vend can be used to test the machine operation. Press “Free Vend” then pull door switch out to enter vend mode. The display should read “Free Vend Mode”. Make any selection and watch for operation. NOTE: since door is open you will need to be ready to catch your product in hand.
- It is important to vend 1 selection in a tall bin and 1 selection in a short bin until the controller believes the bin is empty in one of each. This will verify correct max pickup depth. The picker tip should never get closer than 1” to the bottom of the bin or it may try to grab the bin. If product is very thin, you can use a plastic mesh material with large openings that the robot vacuum can not grab if it tries to go down too far. If the vacuum fails to pickup 3x in that bin it will mark it empty. Its good practice to check bins marked empty to make sure its not trying to go down too far.
- Don't forget to turn “Free Vend” off and close the display door for customer operation. When closing the main door tighten the T handle until display reads “Please Insert Money” and then another turn before locking. Your machine is ready to run.

If you have read this manual and still have questions, please call Technical Support at 888-441-3278 Option #3

2. Warranty

FASTCORP ("SELLER") TERMS AND CONDITIONS OF SALE

PRICES.

All prices, quotations, shipments and deliveries by Seller are F.O.B. Seller's facility. All base prices are subject to change upon thirty (30) days' notice and all orders are accepted subject to Seller's price in effect at the time of shipment..

APPLICABILITY, ACCEPTANCE AND MODIFICATION.

These terms and conditions apply to all quotations and purchase orders covering the sale of Seller's products or services. Seller's acceptance of Buyer's order is expressly made conditional on Buyer's acceptance of the terms and conditions set forth herein. The terms and conditions set forth herein constitute the complete agreement between the Seller and the Buyer, and may be accepted only in accordance with their terms. They may not be modified except by written agreement referring specifically to these terms and conditions and signed by a duly authorized officer of Seller. Any provisions of Buyer's purchase order which are inconsistent with the foregoing shall be of no force and effect, unless Seller shall have agreed to a modification of these terms and conditions in the manner set forth herein. Buyer's failure to dissent from the terms and conditions, or Buyer's acceptance or use of the Seller's equipment shall constitute Buyer's acceptance of these terms and conditions. Buyer, by these presents and the acceptance of the goods ordered herein represents and warrants the Buyer is solvent and able to pay for the goods in accordance with these terms and conditions of sale. Any order accepted by Seller shall not be assigned, sold or otherwise transferred by Buyer unless Seller expressly agrees in writing to such sale, assignment or other transfer.

DELIVERY AND DELAYS.

Seller's obligation is to deliver the goods F.O.B. Seller's facility. Risk of loss passes to Buyer at the moment of delivery. Buyer will inspect the products within a reasonable time after receipt thereof and if Buyer fails to notify Seller within thirty days after receipt that the products are defective in any respect, Buyer will have waived any rights or claims against Seller. Orders for products made to Buyer's specifications are not subject to cancellation by Buyer. Products made to Buyer's specifications must be inspected and accepted by Buyer before shipment. After shipment, Buyer shall have no rights or claims against Seller for such products. Delivery dates appearing on Seller's order acknowledgment, or given to Buyer in any other manner, are approximate. Seller will not be liable for any delay in the performance hereof or for any damages suffered by Buyer by reason of such delay it caused or by the occurrence of any contingency beyond the control of Seller including, but not limited to, delays or non-delivery arising directly or indirectly from fires, floods, substantial damage to its plant, accidents, riots, acts of God, open hostilities, declarations of national emergencies, war, terrorist acts, governmental interference or embargoes, strikes, labor difficulties, shortage of labor, fuel, power, materials or supplies, or any other cause or causes (whether or not similar in nature to any of those herein above specified) beyond its control. Seller shall allocate production and deliveries among Seller's customers in its sole discretion.

STORAGE.

In the event that Buyer is unable to accept delivery of parts or equipment at the time of completion and of shipment, Seller may invoice for the total purchase price as if the shipment has been made and; (i) if Seller is able to store such equipment in its own facilities, the Buyer shall pay Seller reasonable handling and storage charges for the period of such storage; or (ii) if Seller is unable to store such equipment in its own facilities, Seller reserves the right to arrange handling and storage in a suitable warehouse for the Buyer, at the Buyer's expense. In cases where handling and storage become necessary, it will become the responsibility of the Buyer to notify Seller when shipment is to be made and to what destination.

ADEQUATE ASSURANCES.

Seller may, at any time, suspend performance of any order or require payment from Buyer in cash, security or other adequate assurance satisfactory to Seller when, in Seller's sole opinion, the financial condition of Buyer or other grounds for insecurity warrant such action.

TAXES.

Any tax which the Seller may be required to pay or collect, through assessment or otherwise, under any existing or future law upon or with respect to the sale, purchase, delivery, transportation, storage, processing, use or consumption of any goods or services provided by Seller to Buyer, including taxes upon or measured by the receipts from sales or services, shall be for the account of Buyer and may be added to the price of goods or services purchased by Buyer. Buyer shall promptly pay the amount thereof to Seller upon demand.

3. LIMITED WARRANTY.

(A). Subject to the limitations specified herein, the DIVI Merchandiser manufactured by Seller is warranted for five (5) years from the date of purchase against defective parts and workmanship for motors, vacuum motors and the DIVI Merchandiser's freezer system consisting solely of the compressor, condenser, evaporator and the refrigerant tubing is warranted for two (2) years from the date of purchase against defective parts and workmanship. Any part or parts which are proven to be defective within the applicable warranty period will be repaired and/or replaced free of charge, provided that, (i) the return of such part or parts is authorized in writing by Seller's Warranty Department (the "Return Authorization"), and (ii) the defective part and a copy of the Return Authorization is returned with transportation charges prepaid to the destination designated by Seller's Warranty Department. All labor charges shall be for the account of Buyer. (iii) Items including but not limited to normal wear, i.e. rollers, hoses, gears are warrantee for two (2) years from date of purchase.

(B). The warranties provided pursuant to Section 7(A) apply only to the original purchaser of the DIVI Merchandiser and are null and void if the DIVI Merchandiser is sold during the period of warranty.

(C). Notwithstanding anything contained herein to the contrary, the limited warranties provided for herein do not apply to: (i) electrical components, wiring, or circuits and/or for all mechanical parts or assemblies damaged as a result of operating the DIVI Merchandiser at other than 115 volts, 60 Hertz current; (ii) incandescent lamps, neon lamps, fluorescent lamps, ballasts, starters, bins and associated components, graphics or other expendable items; (iii) when other manufactured components are installed by Buyer in the DIVI Merchandiser; and (iv) coin mechanisms, bill validators, currency systems, telemetry systems, cashless payment systems, debit card readers, and other accessories not manufactured by Seller installed at Buyer's request.

(D). Seller is not responsible for any cost of service rendered or repairs made by buyer or its agents on merchandise or parts unless authorization to incur expense has been given in writing by Seller prior to incurring such expense.

(E). Seller shall not be liable to Buyer under this warranty if Seller determines that the defect was caused by misuse, abuse, vandalism, improper application, improper operation, improper maintenance, alteration, repair or modification, negligence or use, casualty, fire, flood, storage, handling or any other cause beyond the control of Seller.

(F). THE WARRANTIES PROVIDED FOR UNDER THIS SECTION 7 ARE EXCLUSIVE AND IN LIEU OF ALL OTHER WARRANTIES, OBLIGATIONS OR LIABILITIES. SELLER EXPRESSLY DISCLAIMS AND BUYER HEREBY WAIVES ALL OTHER WARRANTIES, EXPRESSED OR IMPLIED, INCLUDING WITHOUT LIMITATION, WARRANTIES OF MERCHANTABILITY OR FITNESS FOR A PARTICULAR PURPOSE. THE BUYER ACKNOWLEDGES AND AGREES THAT NO OTHER REPRESENTATIONS OR WARRANTIES WERE MADE TO OR RELIED UPON BY BUYER WITH RESPECT TO THE QUALITY AND FUNCTION OF THE GOODS SOLD HEREIN. SELLER DOES NOT AUTHORIZE ANY PERSON, COMPANY OR ENTITY WHATSOEVER TO ASSUME FOR IT ANY OBLIGATION OR LIABILITY IN CONNECTION WITH THE SALE OF SAID EQUIPMENT OR ANY PART THEREOF.

4. LIMITATIONS OF BUYER'S REMEDIES.

Buyer's remedies with respect to any claim arising out of any order, or Seller's performance in connection therewith, including, without limitation, any claim arising out of any defect or alleged defect in any goods or services furnished by Seller, shall be limited exclusively to the repair and replacement of defective parts as specified in Section 7 herein. Without limiting the foregoing, Seller shall not be liable for breach of contract arising out of or in connection with a warranty claim. In no event shall Seller be liable for any damages including, but not limited to, lost profits or other incidental or consequential damages arising out of this agreement or the use or inability to use any of the products including, but not limited to, the DIVI FC (plus any subsequent digits) Merchandiser, even if Seller has been advised of the possibility of such damages, or of any claim by Buyer or any other party.

WAIVER

Waiver by Seller of any breach by Buyer of any of the terms and conditions set forth herein shall not be construed as a waiver of any other breach or the failure of Seller to exercise any right arising from any default of Buyer hereunder shall not be deemed to be a waiver of such right, which may be exercised at a subsequent time.

GOVERNING LAW

This Agreement shall be governed by the Uniform Commercial Code as adopted by the State of Connecticut in force as of the date hereof. Buyer consents to the jurisdiction of the state and federal courts within the State of Connecticut. Service of process by certified or registered mail shall be sufficient to commence suit and obtain a judgment by default. Buyer waives any right to personal service of process. Notwithstanding anything contained herein to the contrary, if Seller so directs, any controversy or claim arising out of or related to this agreement or the performance or breach thereof shall be resolved by binding arbitration in accordance with the rules and procedures then obtaining of the American Arbitration Association. Any action or proceeding by Buyer arising out of or in connection with this transaction, including any claim for Seller's breach of contract or Seller's breach of Warranty, must be commenced within two (2) years after the delivery of the equipment to Buyer except in the case of a claim for Seller's breach of Warranty relating to the DIVI Merchandiser's freezer system as provided for herein which must be commenced within five (5) years after the delivery of the equipment to Buyer.

Credit

All invoices paid after the due date specified within shall accrue interest at the lesser of 2% per month or the highest rate of interest permitted by law. In the event that the Buyer pays any invoice with a credit card, Buyer hereby waives, releases, and discharges any all rights that Buyer may have, under the terms of Buyer's agreement with the credit card provider, to dispute, challenge and/or protest the payment of any Seller invoice.

5. FAMILIARIZE YOURSELF WITH THE NEW ROBOT

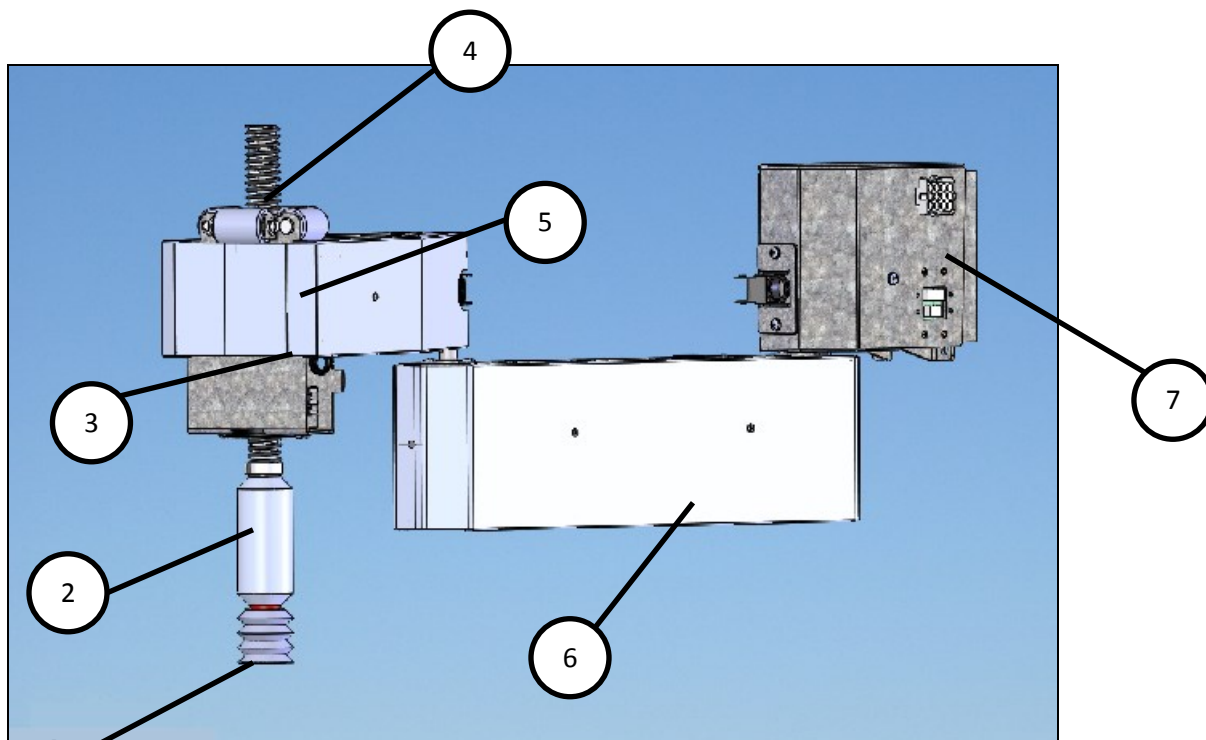

Robot Arm Assembly		
1	2300014	Vac Cup (AKA picker tip)
2	F003-A04168	Weighted Picker Assy
3	F003-A03910	Forearm Assy - with Cover Assy 1100354
4	8018132001	Vacuum Hose
5	F003-A04171	Vac Hose Drive Assy
6	F003-A04147	Humerus Assy - with cover assy 1100354
7		Robot Shoulder Cover

6. TRANSPORT, UNPACKING AND INITIAL SETUP INSTRUCTIONS

A. TRANSPORT CONSIDERATIONS

The DIVI Vendor should always be maintained in an upright position. Failure to do so may result in permanent damage to the vendor. Whenever the DIVI Vendor is transported, always install the shipping brackets that were provided with the machine. Replace cable ties as necessary. Refer to the uncrating instructions for cable tie and shipping bracket installation.



!! ATTENTION!!

ALL SHIPPING BRACKETS MUST BE REMOVED BEFORE APPLYING POWER TO THE MACHINE. FAILURE TO DO SO MAY RESULT IN PERMANENT DAMAGE TO THE ROBOT OR ELECTRONICS.

B. RECEIVING INSPECTION

Upon Receipt and, before removing packing material, inspect the outside of the machine for damage. Remove exterior packing materials and again inspect the vendor for shipping damage. If possible, report shipping damage to the truck driver at the time of delivery. Have the driver note damage on the bill of lading and immediately notify the trucking company. Although the terms of sale are FOB shipping point which requires the consignee to initiate shipping damage claims, Fastcorp will gladly help if a claim needs to be filed.

7. Tools required uncrating the vendor:

- Screw gun with Phillips #2 bit –to remove screws (only if sand boxed)
- Box cutter knife to remove stretch wrap
- Cutting pliers to cut tie-wraps

The DIVI Merchandiser is packaged using the most effective means possible to safeguard the vending machine during transportation and distribution. We encourage you to save the shipping materials for reuse whenever the vendor is shipped.

The cabinet is shrink-rapped after the installation of:

- Four Corner Boards
- Bubble Wrap
- Card Board Panels
 - This serves to protect the graphics and prevent damage to the cabinet and door.
- Optional Sandbox
 - We install a protective wood perimeter barrier onto the skids at the base of the cabinet to prevent damage from fork trucks during warehousing and transport.
REMOVE SHRINK WRAP FROM THE CABINET BEFORE STORING THE VENDOR OUTSIDE.
- Robot shipping bracket / ties

8. Remove the Shipping Materials:

- Use a screw gun with a #2 Phillips bit to remove the retainer screws from the wood perimeter barrier at the base of the vendor.
- Use a box cutter knife to cut the shrink wrap. When cutting the shrink wrap, make all cuts over the corner boards. Failure to do so may cause damage to the Power Supply Cord, Graphics, or paint.
- Store corner boards, card board panels and wood base barrier for future use.
- The shipping skids that are installed onto the DIVI Vendor will accommodate most pump jacks and vending machine lifting devices. It is unnecessary to mount the machine onto a pallet for transport with these in place. The skids are held in place by the (4) Leveling Legs.

9. Remove the Shipping Skids:



The shipping skids can be removed by lifting and supporting the vendor with an approved lifting device and then remove the (4) leveling legs using a 1 3/8" socket wrench. Re-install the leveling legs a minimum of 3/4 ". Store shipping skids for future use.

The shipping skids have center cuts (kerfs) cut through each end and between the leveling legs to allow skids to be split in half and removed using a pry bar if necessary. Please note, splitting the skids will render them unusable in the future. The shipping skids will need to be replaced before the machine is moved again. Adjustable feet will bend / break if shipped without a shipping skid.

10. Adjust the front leveling legs

Level the cabinet using the included bubble level to less than 2° of being level. All legs must be in solid contact with the ground. A maximum of 1" of thread is visible when the leveling leg is fully extended. Do not extend the leg beyond this point. Leveling legs are adjusted using an adjustable wrench, pliers or a 1-3/8" open end wrench. Unscrewing / adjusting the legs down will raise the machine approximately 1/16" per turn of the foot in that corner. If the machine is to be used next to another vendor, compare the top and side for proper alignment. Minimum leg extensions should be used in leveling and alignment to attain greater stability. Make sure that all the leveling legs are in contact with the floor and that the machine does not rock. If you cannot level the vendor, select another location. Do not place any objects under the machine. Leveling is extremely important to ensure proper vendor operation and robot function. Do not program or operate the machine before the leveling process is complete. If preprogramming selections in a warehouse prior to placement, the machine must be leveled again at the new location and all the program selections checked for proper robot to bin alignment.

11. INSTALLING AND POSITIONING THE MACHINE

1. Maintain a distance of at least 3" (7.6 cm) between the rear wall of the vendor and any obstructions to ensure adequate ventilation airflow. If enclosed / built in, airflow in the bottom and out the top must not be obstructed or blocked.
2. Opening the Front Door: The T-Handle keys (if locks are supplied,) can be found in the coin change pocket. The T-Handle lock cylinder and keys that come with each DIVI Vendor are common to all machines shipped from Fastcorp, LLC. All shipping locks should be replaced before the machine is placed on location.
3. Power Supply Cord: The 115v DIVI Vendor power supply cord is equipped with a resettable Ground Fault Circuit Interrupt device (GFCI). Care should be taken when handling the GFCI module. Damage may occur if dropped onto a hard surface. The GFCI unit has an LED light to let you know that the device is working properly. If the GFCI cannot be reset or if the GFCI unit trips immediately after being reset, a replacement cord may be necessary. Contact Fastcorp Service at (888) 441-3278.
4. Verify the machine is level with the included bubble level.

12. SHIPPING BRACKETS.

- The DIVI Vendor makes uses tie wraps to secure the robot arm during transportation. It is necessary to install these tie wraps each time the machine is transported to or from location.
- Freezer Lid Shipping Bracket Removal Instructions: The Freezer Lid Hold Down makes use of a red cable tie to prevent the Freezer Lid from opening during shipping. The cable tie wraps around the Freezer Closed Switch Actuator Plate and the Freezer Closed Switch Mounting Bracket on the right front of the Freezer. Carefully cut the red cable tie and manually lift the freezer lid to make sure there are no obstructions.

13. TURNING ON THE MACHINE

Note: Before turning on the machine, make sure the shipping brackets have been removed. The Robot Arm should move freely in every direction and the Freezer Lid must open and close without restriction.

A. Power Box

The rear main power box is the primary power source for the vendor. It is located on the inside cabinet wall behind or to the side of the Freezer (depending on freezer model.) There is an ON/OFF Power Switch located on top of the power box that supplies power to the freezer, and the power supply located to the left of the Product Delivery Bin on the bottom of the Front Door. The Power Box has 1 input (power cord) and 2 outputs (freezer and power cord to the door power supply.) It also has either (early machines) a fuse or 2 circuit breakers.

B. Power Supply

The power supply is located to the left of the product delivery bin on the bottom of the Front Door. The power supply has an ON/OFF switch located on the left side of the box which supplies power to the VMC, the robot arm, the digital display (if equipped,) Currency/Telemetry systems, and the vacuum.

- a) To turn on the machine, first turn "ON" the power box switch behind the freezer. Then turn "ON" the door power supply switch (left of the delivery bin on the bottom of the door). The Freezer and lamps will turn on, the Robot Arm will present itself at the Delivery Position, the Display will light up, and the machine will be ready for Programming.
- b) Press the VAC button then scroll to Service Menu Option 13 to set the Health Timer so that the machine can be set up before the Freezer cools down. See the Service Menu section for instructions.

SETUP INSTRUCTIONS

14. Currency Systems

The DIVI Vendor supports only 24 - 34 volt Multi-Drop Bus (MDB) Money Systems

The DIVI Vendor is compatible with any MDB compliant, level 2 or higher coin mechanism or bill validator as well as most card readers and telemetry systems.

The DIVI vendor leaves the factory pre-wired with a DEX port located inside the door near the left side of the window frame. To collect sales data using the DEX port, insert the plug from your DEX handheld into the port and pull out the pin on the 3 position service/door/interlock switch. The door switch is located below the threads of the T-Handle bolt on the back of the door. It is necessary for the machine to have a unique identification number entered into the serial number field on the Service Menu Option 17) Machine Serial Number (defaults to the VMC Board serial number). Your DEX interrogator may need to be initialized prior to the first read to allow the vendor to be recognized.



Installing Peripherals

*Coin and bill acceptors as well as card readers and other MDB peripherals should be installed and their function tested prior to placing the vendor into service. Always **turn OFF the Power Supply rocker switch** (bottom of door under Delivery Bin) before plugging or unplugging MDB peripherals. Hot plugging MDB devices will result in a blown control board.*

Coin Mechanism/Changer

The Coin Changer mounts onto (3) screws on the back of the door inside the security door. Make sure that all (3) mounting screws are tightened. The coin changer harness can be plugged directly into the MDB harness (VMC location J8 MDB) or it can be plugged into the Bill Acceptor Y-Harness.

Fill all coin tubes until a coin from each tube overflows into the cash box. Test the operation of the coin changer after filling the tubes.

If the display reads, "Machine Must Be Set Up", [program a selection](#) and then insert coins and test the coin changer for proper operation.

While testing, push the coin return to verify that coins will dispense into the coin return cup.

Coins may be dispensed by pressing the payout keys on Service Keypad or by going to Service Menu Option 18) Fill / Dispense.

Bill Acceptor

Remove the lower block-off plate from the door by removing the four #8 nuts with an 11/32" socket wrench. Install the Bill Acceptor onto the studs using the four #8 nuts that had previously held on the block-off plate. Some bill validators may require the use of stud extensions. These are usually supplied with the bill validator and should be used only if necessary. Tighten all four nuts to secure the assembly, then turn ON the vendor and test for proper operation.

Card Readers and Telemetry Systems

There are many card readers and telemetry systems available. Fastcorp has tested many of these devices to insure compatibility with our software. On occasion, a new product will be introduced which may require further testing to insure compatibility. If you have any questions relating to your MDB peripherals, please call Fastcorp Technical Service.

Card Readers may be installed directly above the Customer Keypad. Remove the upper block-off plate and install on the four available studs using the four block-off plate #8 retainer nuts and an 11/32" socket wrench.

Note - Store the block off plates in a safe place for future use.

15. FREEZER MAINTENANCE DIVI

Viewing freezer temperature:

While in Vend Mode (indicated by “Please Insert Money” on the scrolling marquee on the Digital Display), press the “*” key on the Customer Keypad. The current temperature will be displayed on the Digital Display.

Temperature Adjustment:

Depending on the freezer model, some machines have adjustable temperature controllers.

Standard Machines

If available, the temperature may be adjusted by turning the Thermostat Dial located on the outside back of the freezer next to the left freezer lid hinge. The scale ranges from 1 which is the warmest setting to 7 which is the coldest. The recommended factory setting is “5”. Three to four hours after powering up the Vendor, the temperature inside the Freezer should drop to about – 10°F / -23°C. The operating temperature for the standard ice cream and food vendor will vary based on the prevailing temperature at the machine. Typically the operating range should be between -5°F/-20°C and -15°F/-26°C.

Extreme Cold Machines

Extreme cold machines should reach operating temperature approximately 4 hours after being turned on. Typically, operating temperature ranges between -30 °F / -34°C and -40°F / -40°C. The temperature may be viewed by pressing the “*” key while in Vending Mode (Please Insert Money).

Servicing the Freezer:

The standard chest freezer inside the DIVI does not self-defrost. The freezer chest requires maintenance when ice begins to affect the vend cycle, product loading, or closing the freezer lid. The refrigeration system does not require any maintenance. Depending on the location’s moisture level (relative humidity) and frequency of operation, ice may accumulate inside the Freezer above the level of the bins.

FASTCORP recommends keeping the plastic ice scraper (provided with the machine), and a 9” by 11” piece of cardboard or plastic inside the machine. Place the plastic under the area to be scraped to prevent the ice from falling into the bins. This entire process should only take a few minutes. Wipe the area with a clean dry towel after the frost has been removed. This process should be repeated each time the Vendor is serviced to prevent large scale ice buildup that will require a time consuming freezer defrost.

DEFROSTING THE FREEZER:



Do not use mechanical devices or other means to accelerate defrosting other than the included ice scraper. Failure to comply could result in freezer damage, fire, explosion, and death.

- (1) Depending on usage, temperature, humidity, and maintenance practices, frost will accumulate. It will eventually become necessary to defrost the freezer.
 - (i) Press the “LOAD” button, allow freezer to open completely, then turn OFF machine and unplug the vendor.

Note: Take a picture or verify that a bin plan-o-gram is correct to your freezer / bin layout.
 - (ii) Remove all of the bins.

Knock ice off the bins as best as possible and set aside to dry thoroughly.
 - (i) Place the product in an appropriate holding container that will keep product at its correct temperature.
 - (ii) Scrape off and remove ice from the freezer chest.
 - (iii) Drain freezer water into a pan. Plugs are located on the inside freezer floor and outside front of the freezer. A wet/dry vac or a sponge may be used depending on the volume of water.
- (2) Ensure freezer is completely clean and dry before proceeding. Wet bins will deteriorate quickly and will freeze in place. Install bins in their proper locations, turn on the freezer, and load product after the freezer reaches operating temperature.
 - (iv) Test-vend each selection to verify accuracy of the robot. Edit locations as necessary.
- (3) Under most conditions, the DIVI Vendor may lose power for up to 12 hours without compromising the quality of the product if the freezer remains closed. If freezer temps reach unsafe levels, the health sensor will activate and the machine will be placed out of order.

16. Health Sensor Active Guidelines

When the machine is placed out of service with a Health Sensor Active, the **product must be inspected before the machine can be reset and placed back in operation.** Often only the top two or three items in each bin will have melted. If the machine loses power for an extended period of time, the product must be discarded and the freezer and bins will have to be cleaned before the machine can be placed back in service. See [sanitation and food safety](#) info.

Ice Cream and Food Machines:

a) The Health Sensor will go active and the vendor will go out of service if the freezer maintains a temperature warmer than 0°F / -18°C for a period in excess of 15 minutes.

Extreme Cold Machines:

b) The Health Sensor will go active and the vendor will go out of service if the vendor maintains a temperature warmer than -25°F / -32°C for a period in excess of 15 minutes.

17. Error Recovery:

a) When a machine is out of service, the error message may be retrieved by pressing the “#” key. If the error is Health Sensor Active, the machine will not accept money until the error has been reset and the machine has reached operating temperatures.

18. VAC Keypad Security Feature:

a) The Service Keypad “VAC” button must be pressed to release the Keypad Security Feature and allow normal use.

19. Sold out bins and bin load errors:

a) Sold out bins and bin load errors will trigger a display when the machine door is opened at the time of service. Press “#” to scroll through individual messages or press “*” to exit to 1) Change Price menu. Press the “VAC” button to release the keypads. Press “Load” (freezer lid will open, robot arm will move to the rear loading position) and then press “Close” (the Robot Arm will return to the delivery position) to clear the error and reset the machine. “Load” then “Close” will signal the VMC that the machine has been filled. Load/Close will automatically set a Health Sensor delay for 75 minutes.

20. Health Sensor Active:

A **health sensor active** code along with an out of service machine signifies that a machine powered up with the freezer above its maximum allowable safe temp. This usually signifies that the power to the machine was interrupted for a prolonged amount of time. The product / food in the freezer may be spoiled and must be inspected before restoring the machine into service. Spoiled food must be discarded.

Errors are cleared by pressing the VAC button and # when the door is opened. Press “Load” (freezer lid will open, robot arm will move to the rear loading position) and then press “Close” (the Robot Arm will return to the delivery position) to clear the error.

If the machine must be operated for testing purposes, the Health Sensor may be bypassed for up to 4 hours. See Programming Instructions, Service Menu Option # 13) [Health Timer](#).

See also [sanitation and food safety info](#).

21. Vendor Errors:

All DIVI Vending Machine errors other than Health Sensor Active are automatically cleared as soon as the machine door is opened or power to the machine is cycled off and back on.

22. VAC - Error Log:

An error history can be accessed by pressing the VAC button on the Service Keypad. Up to ten errors are stored in the Error Log with a time and date stamp. Entries may be viewed in reverse order of occurrence by pressing the “VAC” key. Each time the “VAC” key is pressed, the log will scroll back one entry. Press “*” to exit.

23. PRODUCT DISPLAY SYSTEM

- Determine what products will be vended and what the sale price will be.
- Locate the Product Card Pack and the Price Sticker Sheets from inside the delivery bin.
- Locate the Display Cards that correspond with the products that will be vended from the machine.
- Locate the Price Stickers that will correspond with each product.
- Access the Display Card Holder by sliding it up and out of the light housing.
 - Install the Price Stickers and then the Display Cards in the appropriate positions and on the display card holder.
 - Slide the display card holder in front of the light housing when done.

24. BIN SETUP/ PLAN-O-GRAM

The DIVI Vendor utilizes a bin system to hold product. The bin system is made up of a number of bins of various shapes and sizes. The type and size of the bins depends on the size and shape of the products being vended. Every machine comes preconfigured with a specific bin layout or bin plan-o-gram. The configuration of the bin plan-o-gram inside your machine may be modified to accommodate different size bins as your product line changes. If you have any questions relating to modifying your plan-o-gram contact the Fastcorp Service Department.

Product Loading:

- Press “LOAD” on the Service Keypad. The Freezer Lid will open and the Robot Arm will move to the rear cabinet loading position. Bins may be filled without being impeded by the Robot Arm.
- Press “CLOSE” on the Service Keypad when bins have been filled. The Robot Arm will return to the front delivery position and the Freezer Lid will close. The Health Timer will automatically be set to 75 minutes to allow the freezer to recover from any possible temperature loss due to loading.
- “Load” then “Close” will signal the VMC that the machine has been filled. Load/Close will automatically set a Health Sensor delay for 75 minutes.

Notes:

It is important to program the appropriate bins as short bins. Short and tall bin locations will vary based on the specific freezer in your machine. Bin height dictates how far down the picker tip will travel to get product. The short bins are shaded in Fig 1 below (IC plan-o-gram). If short bins are programmed as tall bins, the robot will make contact with the bottom of the bins and attempt to pull them out, resulting in possible machine failure

(out-of-order). If tall bins are programmed as short bins, the machine will only vend product based on the height of a short bin. The robot will leave product at the bottom of the tall bin and flag it Out-Of-Product. The vending travel limits on the Up/Down axis can be adjusted by going to the Service Menu #21 Up Down Travel Limits and follow the prompts.

25. Loading:

1. Remove bins, one at a time. Open each bin and move product to the top of the bin. Place new product below the older product so that the older product will be vended first.
2. Product should always be level inside the bins. Alternate product direction when loading cone bins.
3. Wrapper seams must always face down.
4. Styrofoam spacers should be used to prevent small products from shifting in the bins.
5. No product should have more than ½-inch of space from left to right and from front to back within each bin.

General Considerations:

1. Fastcorp recommends that a bin plan-o-gram form be filled out and attached to the inside of the machine. The product name, price and bin number can also be written directly on each bin. We also recommend that the machine is programmed to leave one product at the bottom of each bin to make it easier for the route driver to match products with a location inside the freezer when servicing the machine.

2. Keep a copy of each machine's bin plan-o-gram on file as a reference and as a backup if necessary.

3. Each bin can be used as a tall bin or a short bin depending on where it is placed inside the freezer. Short bins are approximately half the height of a tall bin and are located over the compressor. Cut a tall bin at the perforation and it becomes a short bin.

4. Always load product from the bottom up so that the oldest product will be vended first (FIFO: First In First Out).

5. The standard bin configuration will accommodate most novelty products. Spacers and inserts are provided for products such as ice cream cones, ice cream sandwiches, push-ups, etc. Alternative bin shapes and sizes are available to accommodate most products.

6. Always keep an extra set of bins on hand to be used in the event of a meltdown. Bins can be removed and replaced quickly.

7. There should not be more than one half of an inch distance from left to right and front to back between the product and the bin. Use smaller bins or proper spacers to ensure consistent product retrieval.

8. Fastcorp recommends stacking uneven products with every other one rotated 180° to keep the stack of product stacked evenly and straight.

9. Fastcorp recommends placing the best-selling items at the center of the freezer. This shortens the robot travel distance and will reduce vend cycle time.

I.C. PLAN-O-GRAM

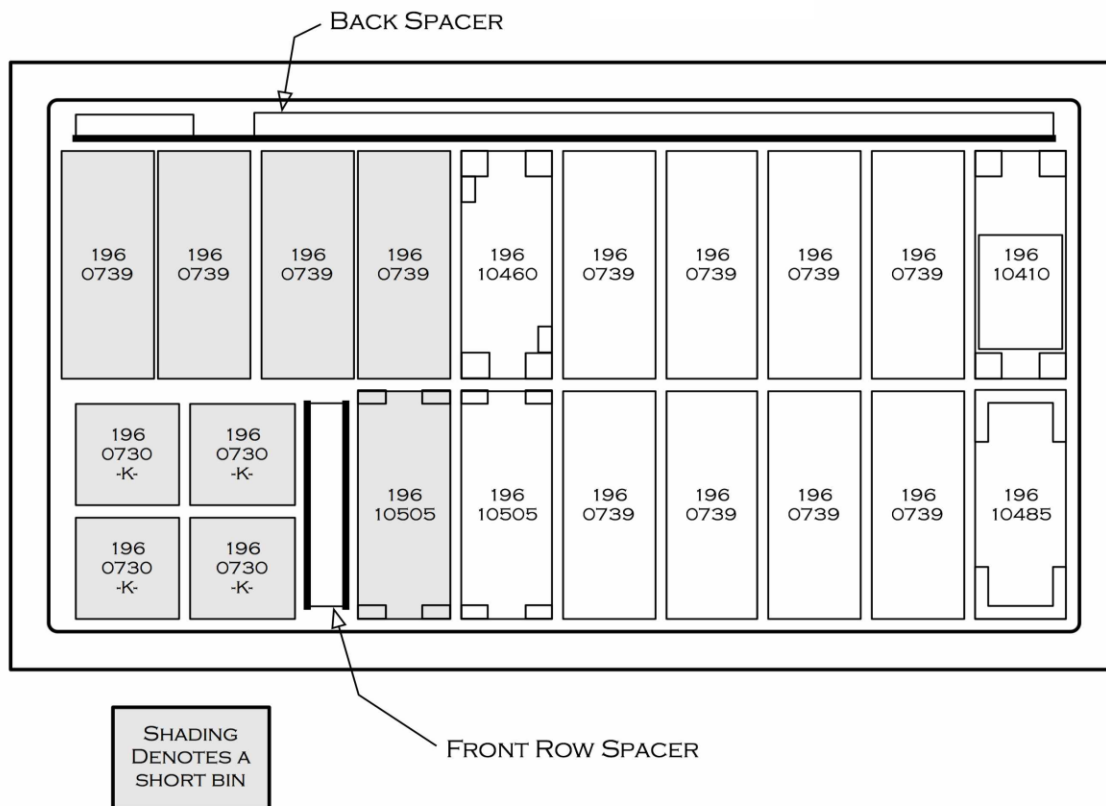

Figure 1 Sample Plan-O-Gram (Aerial View)

26. PROGRAMMING

Introduction. The machine comes from the factory without any preset selection numbers or bin locations in memory. All information is entered during initial setup and programming. Programming is menu driven and programming menus are accessed in Service Mode. Simply scroll through the menus until the desired function is reached. Once inside a menu function, the computer will prompt the user to enter the required information.

The machine enters Service Mode every time the cabinet door is opened.

NOTES:

- PRESS THE VAC BUTTON ON THE SERVICE KEYPAD TO DISABLE THE SECURITY-LOCKING FEATURE (DISPLAY READS - "KEYPAD IS LOCKED") AND ENABLE USE OF THE CUSTOMER KEYPAD.
- Once enabled, press the "*=Next" key on the Customer Keypad to scroll through the Service Menu options. Press the "D" key to scroll in reverse order.
- If the machine is programmed in one location (for example in your warehouse) and transported to another, it is important to re-level the machine at the new location and perform test vends on each selection. Edit bin locations as necessary.

Closing the Door - When closing the machine door it is important to NOT over-tighten the T-Handle. Rotate the T-Handle until the Display changes to, "Please Insert Money", then turn the handle two additional revolutions and push it in. Over-tightening the T-Handle may result in damage to the T-Handle Assembly and may prevent normal operation.

27. SERVICE MENU OPTIONS:

CHANGE PRICE: Allows the prices to be changed.

SALES METERS: Allows sales data to be viewed.

EDIT SELECTION: Allows existing selections and bin positions to be edited. Allows bins to be added to existing selections.

CREATE SELECTION: Allows a selection to be created.

DELETE SELECTION: Allows a selection to be deleted.

SELECTION NUMBERS: Allows programmed selection numbers to be viewed. (Use to check for erroneous selections).

SET DATE & TIME: Allows date and time to be set or viewed.

AUTO VENDS: Used internally to cycle-vend machines under test.

SERVICE PHONE #: Allows service phone number to be set. The number is displayed when the machine is out-of-order. (Do not use FASTCORP'S phone number).

SALES PIN CODE: Allows PIN code to be set and viewed for machine auditing. # 2) Sales Meters may be accessed from outside the machine without opening the door.

VEND BLOCK: Allows the machine to be disabled for up to 4 predetermined periods of time.

VEND BLOCK PIN CODE: Allows a PIN code to be set to access the vend block function without opening the door.

HEALTH TIMER: Suspends Health Control for 1,2,3 or 4 hours; Set freezer temperature scale to display in either Fahrenheit or Centigrade; Set mode for Health Sensor: NAMA Ice Cream, Test, Super Cold or Food.

PROGRAM VERSION: Displays version of firmware installed on VMC.

DISPLAY LANGUAGE: Allows the programmer to choose the language displayed on the screen. Choose from English, German or Spanish. One additional language may be added to memory if necessary.

LINE MODE: Shortens vend time by leaving the freezer lid open between vends. Lid opens when currency has been detected. Lid will close if there is no activity for 20 seconds.

MACHINE SERIAL NUMBER: Allows the programmer to enter up to a 10-digit serial number for machine identification during DEXing.

FILL / DISPENSE: Allows coins to be dispensed from tubes while displaying a coin count.

TOKENS & COUPONS: Allows coupons and tokens to be recognized as free or valued vends and records sales in appropriate DEX fields.

FIELD TEST: Allows the machine to run in a diagnostic mode to allow for quick troubleshooting.

UP/DOWN TRAVEL LIMITS: This feature allows the customer to adjust how deep the Picker Tip will descend into both tall and short bins. NOTE: Increasing the number will cause the vacuum pump to travel further into the bin. Changing this value by 5 represents a change in travel of 1”.

VERIFY ALL BINS: Automatically moves robot over each bin position. Allows user to verify and edit bin programming.

MDB SETTINGS: Allows specific settings for currency system:

Force Vend - Customer cannot use vendor for the purpose of changing bills. If a bill is inserted and the coin return button is pressed, it is ignored. A selection must be chosen. Only exception is when the selection is sold out. No Cheat - Money is not accepted if there is a possibility where the customer will be short-changed. Bills are not accepted if there is not adequate change for a failed vend.

Change Bill - Similar to forced vend but focuses only on bills that have been accepted, whereas force vend is also concerned with coins.

Hold Lost Credit - Funds that could not be returned to a customer during a vending are available for another transaction.

Multi Vend - Change is not automatically returned after a transaction, but held for another transaction. Press the coin return button to receive your change.

Lev 2 Coin Mech - When set to “N” (default), the coin mechanism will determine optimum change. If set to “Y”, the VMC will determine what coins to give back as change, regardless of the capabilities of the coin mechanism. Power to the VMC must be cycled off and back on after changing this setting.

Instant Reval - When set to “Y” (default), a stored value cashless device can receive revaluation credit as soon as coin or cash is inserted into the vendor. When option is set to “N”, revaluation occurs when a major action is taken such as pressing the coin return. This option is only necessary for older cashless systems where the number of revaluations per credit device is limited.

SOFT DROP: Allows enabling and setting the “Soft-Drop” feature that lowers the product before it releases it into the product chute. Delay time is how long the picker tip waits at delivery position to allow vacuum to dissipate and product to release from picker tip.

28. CALIBRATING THE ROBOT ARM

If the message on the Display reads, "MACHINE NOT SET UP", you will need to calibrate the robot arm. This typically only appears when the VMC or Robot Arm is first calibrated to the cabinet.

Scroll to menu # 4) Create Selection.

a) Press the "#" key to create a selection. You will be prompted to "SET ARM AT LEFT WALL". Position the arm shown in figure 9A. Press the "#" key to accept. Display will show "SELECTION STORED"

(1) Now you will be prompted to "SET ARM AT DELIVERY". Position the arm as shown in figure 9B. Press the "#" key to accept. Display will show "SELECTION STORED"

(2) Display should return to "4) CREATE SELECTION"

(3) You may now program your selections as described in the "PROGRAMMING YOUR MACHINE" section.

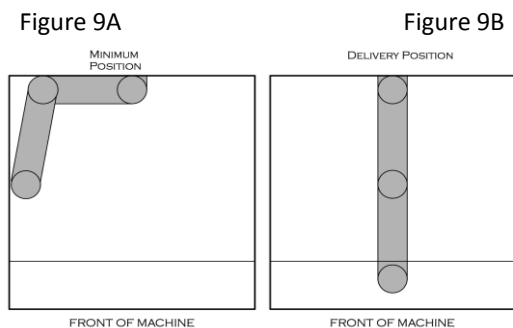

29. Re-calibrating the Robot Arm

If the Robot Arm or VMC Board needs to be upgraded or changed, the Robot Arm calibration will need to be erased and recalibrated. The arm may be recalibrated without losing programmed information, but take care to follow the instructions, precisely.

a) Press the VAC button on the Service Keypad to release the security locking feature.

b) Go to the Service Menu and press the "*" key repeatedly until the display reads, "4) Create Selection". Press and hold the Reset button. The VMC will beep as you hold the Reset button. The display will immediately read:

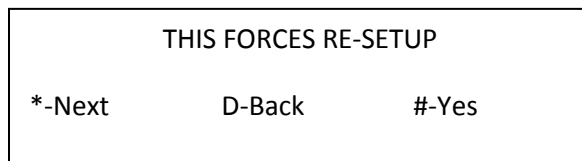

c) Continue holding the Reset button. The VMC will continue to beep. The display will change to:

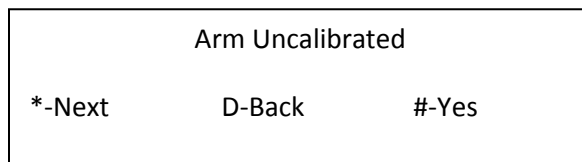

d) Release the reset button and press the #-Yes button. You will be prompted to "SET ARM AT LEFT WALL". Position the arm shown in figure 9A in the previous section. Press the "#" key to accept. Display will show "SELECTION STORED"

e) Now you will be prompted to "SET ARM AT DELIVERY". Position the arm as shown in figure 9B in the previous section. Press the "#" key to accept. Display will show "SELECTION STORED"

30. ERASE ALL PROGRAMMED INFORMATION:

a) On occasion it may become necessary to erase all programmed and sales data.

b) Press the VAC button on the Service Keypad to release the security locking feature.

c) Go to the Service Menu and press the "*" key repeatedly until the display reads, "4) Create Selection". Press and hold the Reset button. The VMC will beep as you hold the Reset button. The display will immediately read:

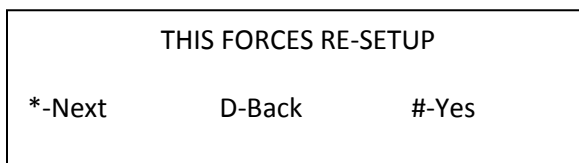

d) Continue holding the Reset button. The VMC will continue to beep. The display will change to:

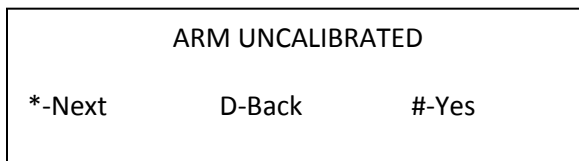

e) Continue holding the Reset button. The VMC will continue to beep. The display will change to:

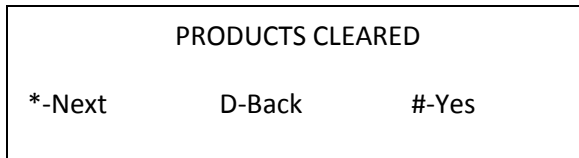

f) Release the reset button and press the #-Yes button. You will be prompted to "SET ARM AT LEFT WALL". Position the arm shown in figure 9A in the previous section. Press the "#" key to accept. Display will show "SELECTION STORED"

g) Now you will be prompted to “SET ARM AT DELIVERY”. Position the arm as shown in figure 9B in the previous section. Press the “#” key to accept. Display will show “SELECTION STORED”

h) You may now [program your selections](#) as described in the “PROGRAMMING YOUR MACHINE” section.

31. SERVICE MENU:

A. Change Price –

(1) Changes the Price of programmed selections.

Display		Programming Instructions
1) Change Price		a) Press the # = Yes key to enter Menu Option
* = NEXT	D=Back #=Yes	
Edit Selection # - Exit		b) Enter the selection number
A1 Price: 1.00 * = Exit * = Exit		c) Type over the price. Press # to accept
A1 Price: 1.50		d) Press the # = Accept key to enter the price change
* = Exit * = Exit		

1.

B. SALES METERS –

(1) Provides access to Total and Resettable Meters. Total Meter displays Total Sales data in units sold and currency. The Resettable Meter displays total sales data for each selection in units sold and currency. Resettable Meter sales data may be cleared and reset to 0 after each service visit.

Display		Programming Instructions
Programming Instructions		a) Press the #=Yes key to enter Menu Option
* = Next	D = Back # = Yes	
Total Vends * = Nxt 975		b) Total Meter count of units sold. Press *=Nxt to continue.
Total Value * = Nxt 1575.30		c) Total Meter count in currency Press *=Nxt to continue
Selection 25	A1 40.00	d) Press the * key to scroll through selection numbers to view sales data.
Selection 25	A2 72.50	e) Press the * key to scroll through selection numbers to view sales data.
Reset Vends	* = Nxt 225	f) View Total Resettable units sold. Press *=Nxt to continue
Reset Value	* = Nxt 375.25	g) View Total Resettable Sales in currency. Press *=Nxt to continue.
Reset Card	* = Nxt 115.50	h) View Total Resettable Sales in Credit Card. Press *=Nxt to continue.
Clear All OK?	* = No # = Yes	i) Press # to clear Resettable Meters and continue.
Resettables Cleared		j) Long beep and Resettable Meters will be reset to 0.

C. EDIT SELECTION-

Allows you to change the price, edit bin location or add multiple chained bins to a single selection.

Display		Programming Instructions
3) EDIT SELECTION		a) Press the #=Yes key. The robot will go to the delivery point and the freezer lid will open.
* = Next	D = Back # = Yes	
ENTER SELECT # # - Exit		b) Enter selection number to be edited.
A1 Price: *=Exit	1.00 #=Accept	c) Type over the price and press the “#” key.
A1 *=Cancel	Move The Robot #=Accept	d) Adjust the position of the robot over the bin. Press “#” key to save the bin location.
Bin Height: *=Change	Tall #=Accept	e) Select Tall or Short by pressing the *key. Press # to accept.
More Bins? *=No		f) Press the #=Yes key to add additional (chained) bins or press * to exit menu.
	#=Yes	

D. CREATE SELECTION –

Create new selections, with the ability to chain multiple bins to a single selection.

NOTE:

WHEN POSITIONING THE ROBOT OVER A BIN, THE ELBOW SHOULD POINT TO THE OPPOSITE SIDE OF THE FREEZER FROM THE BIN. EXAMPLE- IF THE BIN IS LOCATED ON THE LEFT SIDE OF THE FREEZER THE ROBOT ELBOW SHOULD POINT TO THE RIGHT SIDE AND VICE VERSA.

*** BINS NEAR THE CENTER OF THE FREEZER SHOULD BE PROGRAMMED WITH THE ELBOW POINTING TO THE RIGHT SIDE***

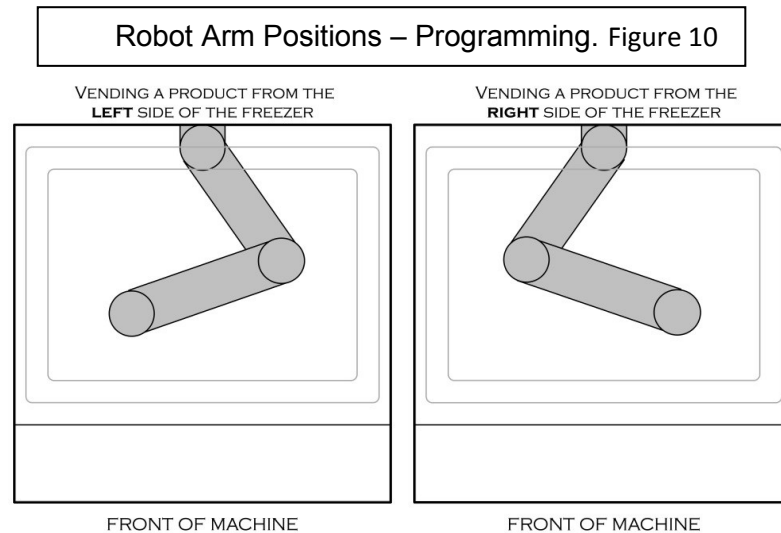

Display		Programming Instructions
3) CREATE SELECTION		a) Press the #=Yes key to enter Menu Option.
* = Next	D = Back # = Yes	
ENTER SELECT # A1		b) Enter selection number to be created.
# - Exit		
A1 Price: *=Exit	1.00 #=Accept	c) Type in the price and press the # key. The robot will go to the delivery point and the freezer lid will open.
A1 *=Cancel	Move The Robot #=Accept	
Bin Height: *=Change	Tall #=Accept	e) Select Tall or Short by pressing the * key. Press # to save this setting.
More Bins?		
*=No	#=Yes	f) Press the #=Yes key to add chained bins. Press * to exit.

E. SELECTION #S –

View programmed selection numbers.

Display		Programming Instructions
6) SELECTION #s		a) Press the #=Yes key to enter Menu Option.
* = Next	D = Back # = Yes	
Programmed: A1		b) Press the #=Next key to scroll through programmed selection numbers. Press *=Exit to exit menu.
*=Exit	#=Next	

F. SET DATE & TIME –

Set or view the current date and time.

Display		Programming Instructions
7) SET DATE & TIME		a) Press the #=Yes key to enter Menu Option.
* = Next	D = Back # = Yes	
TIME - <u>10:35</u>		b) Enter a 4-digit time in AM/PM format. Press #=SAVE.
*-EXIT	#-Save	
TIME - <u>10:35</u>		c) Select "1" for AM or "2" for PM.
1-AM	2-PM	
TIME 10:35AM		d) The programmed time is momentarily displayed.
DATE *-EXIT	08/19 #-SAVE	
YEAR *-EXIT	10 #-SAVE	e) Enter the year in a 2-digit format. Press #=SAVE.
SAVED		
		f) Time and Date is saved..

G. AUTO VENDS –

Used internally to cycle-vend machines under test. Machine will automatically cycle through all programmed selection numbers repeatedly at 3 minute intervals until option is turned off. After Auto Vends is enabled, pull Service Switch “out”. Push the Service Switch “in” to stop. Go back to 8) Auto Vends and follow instructions to turn Auto Vends “OFF”.

Display			Programming Instructions
8) AUTO VENDS			a) Press the #=Yes key to enter menu option.
* = Next	D = Back	# = Yes	
AUTO VENDS *-CHANGE		N #-EXIT	b) Press *-Change to scroll from “N” to “Y”
AUTO VENDS *-CHANGE		Y #-EXIT	
*-EXIT		#-SAVE	
AUTO TEST IS ON			d) Momentary display.

H. SET SERVICE PHONE #

Enter, update, or view your service phone number. This programmed number will appear on the display screen in the event that the machine goes out-of-order.

Display			Programming Instructions
9) SET SERVICE PHONE #			a) Press the #=Yes key to enter Menu Option.
* = Next	D = Back	# = Yes	
* save	Phone (###) ### - #### ABCD=() _ -	# ex	b) Type in service phone number. Use the “ABCD” code to format your service phone number. A=(, B=) , C=SPACE , D= -
	Phone (555) 555 - 1234		
			c) Press *save to save your service number and exit.

I. SALES PIN CODE -

*View or change the PIN code that will allow access to Sales Meters without opening the door. While in “Please Insert Money” mode, Press # * and the four numbers you selected.*

Display			Programming Instructions
10) SALES PIN CODE			a) Press the #=Yes key to view or change sales pin code.
* = Next	D = Back	# = Yes	
*-EXIT	Sales PIN: #*1234	#-SAVE	b) Sales Pin Code is factory set at #*1234. Use factory setting or type over four new digits and press the #-Save key. Type this code when you are in “Please Insert Money” mode to gain direct access to Sales Meters.
	SAVED		
			c) Press # to save the new PIN

J. VEND BLOCK -

Block out vending up to four times per day, seven days per week. Time and date must be entered correctly in SET TIME and DATE programming. *NOTE: When Vend Block is ON, vending is OFF.

Display		Programming Instructions
11) VEND BLOCK		a) Press the #=Yes key to enter Menu Option.
* = Next	# = Yes	
D = Back		
1 BEGIN *-SAVE	01:00 #-NEXT	b) Enter the start time for the first Vend Block. Press *=Save to store time.
1 BEGIN 1-AM	01:00 2-PM	c) Enter "1" for AM or "2" for PM. Display will advance.
BEGIN PERIOD 1 1:00am		d) Block 1 "on" time is displayed momentarily.
1 END *-SAVE	10:00 #-NEXT	e) Type the time you want vending to resume and press *- Save.
1 END 1-AM	10:00 2-PM	f) Enter "1" for AM or "2" for PM. Display will advance.
END PERIOD 1 10:00AM		g) Block 1 "off" time is displayed momentarily.
Sunday *-CHANGE	OFF #-NEXT	h) Press # - Next to scroll through all days, press *- Change to select a day.
SAVED		i) After scrolling through all days to Saturday, display will show that your choices have been saved.
2 BEGIN *-SAVE	12:00AM #-EXIT	j) Enter the start time for the second Vend Block or press # to exit.

K. VB PIN CODE

Set or alter the VEND BLOCK option from the outside of the machine without opening the door by using a PIN code.

Display		Programming Instructions
12) VB PIN CODE		a) Press the #=Yes key to enter Menu Option.
* = Next	# = Yes	
D = Back		
VB PIN *-EXIT	##5678 #-SAVE	b) Vend block pin code is factory set at ## <u>5678</u> . Use factory setting or type over four new digits and press the #-Save key. Type this code when you are in "Please Insert Money" mode to gain direct access to VEND BLOCK.
SAVED		c) Press # to save the new PIN.

L. HEALTH TIMER -

This setting allows the health sensor to be bypassed for a short time. Secondary options are display mode (°F or °C) and Health control mode. A test option is available for NAMA and for Health inspector's use.

NOTE: Health Timer resets to 0 if power is cycled off and then on, again.

Display			Programming Instructions
* = Next	13) HEALTH TIMER D = Back	# = Yes	a) Press the #=Yes key to enter Menu Option.
* = Next	HEALTH TIMER: 0Hrs D = Back	# = Yes	b) Press *=Next to scroll from 0 to 4 hours.
* = Next	HEALTH TIMER: 2hrs D = Back	# = Yes	c) Press #=Yes to start timer.
* = Next	DISPLAY FAHRENHEIT D = Back	# = Yes	d) Press * to select Fahrenheit or Centigrade. Press # to accept.
* = Next	NAMA Ice Cream D = Back	# = Yes	e) Choose Health Control Mode. Press *=Next to scroll: <ul style="list-style-type: none"> • NAMA Ice Cream (Default) • NAMA Test mode. This does not change operation mode. • Food • Super-Cold Then press #=Yes

M. PROGRAM VERSION -

Shows the date and software version installed.

Display			Programming Instructions
* = Next	14) PROGRAM VERSION - D = Back	# = Yes	a) Press the #=Yes key to enter Menu Option.
	FASTCORP GEN 4 UNIVERSAL vX.XXY		b) Program version (X.XX) and revision (Y) are displayed. Press any key to continue.

N. DISPLAY LANGUAGE

Allows the programmer to change the language of all external text and all programming.

English, German and Spanish languages reside in the software. One additional language translation may be added to the existing software subject to availability.

Display			Programming Instructions
* = Next	15) DISPLAY LANGUAGE D = Back	# = Yes	a) Press the #=Yes key to enter Menu Option.
* = Next	English D = Back	# = Yes	b) Press *=Next to scroll through language choices. Press #=Yes to accept.

O. LINE MODE -

Line mode shortens the time between vends by holding the freezer door open between vend cycles. If there is no activity for 20 seconds the Freezer Lid will close. (Default setting is OFF).

Display			Programming Instructions
* = Next	16) LINE MODE D = Back	# = Yes	a) Press the #=Yes key to enter Menu Option.
* = Next	LINE MODE: ON D = Back	# = Yes	b) Press the *=Next key to scroll between options. c) Press the #=Yes key to confirm the selection.

P. MACHINE SERIAL NUMBER -

Program the serial number of the vendor into the VMC memory so that an external data retrieval unit (DEX) can include the serial number when uploading sales information. Up to 10 digits are allowed. Defaults to VMC Board serial number.

Display			Programming Instructions
* = Next	17) Machine Serial # D = Back	# = Yes	a) Press the #=Yes key to enter Menu Option.
SN *-Exit	0000000000 #-Save		b) Enter 10 digit ID number (asset #, machine serial #, etc.). Press #-Save.
MACHINE SN SAVED			c) Save serial number is confirmed.
USE FOR CHANGER SN?			d) Select 1 to assign this number to coin changer. Select 2 if no.
1-YES	2-NO		d) Select option 1 or option2.

Q. FILL / DISPENSE:

Allows coin count to be viewed for up to 5 coin changer tubes. Coins may be dispensed from tubes 1 through 5

Display			Programming Instructions
* = Next	18) FILL / DISPENSE D = Back	# = Yes	a) Press the #=Yes key to enter Menu Option.
Select Tube 1 to 5 # - EXIT			b) Enter any tube number: 1 to 5 to dispense a coin and view coin count.

R. TOKENS & COUPONS –

This allows the machine to recognize coupons and tokens as free vends when the Promotional feature is on. Item and price will be recorded as a free vend in the DEX report.

Display			Programming Instructions
* = Next	19) TOKENS & COUPONS D = Back	# = Yes	a) Press the #=Yes key to enter menu option.
= Change	Tokens / Coupons off #=Accept		b) Press the "" key to scroll between "On" and "Off". c) Press the "#" key to accept selection.

S. FIELD TEST

Enters a diagnostic mode to allow troubleshooting assistance.

Display			Programming Instructions	
* = Next	20) FIELD TEST D = Back	# = Yes	a) Press the #=Yes key to enter Menu Option.	
Press # to Exit Test			b) Second line displays changes to the position of switches and encoders. c) Move any motor by pressing the associated Service Keypad key. d) Press "VAC" key. The Vacuum Pump will turn on then slowly turn off.	
S	Press # to Exit Test XXX	E	YYY	e) Press * key to inspect position sensor values for Shoulder and Elbow Sensors.

T. U/D TRAVEL LIMITS

This feature allows the customer to adjust how deep the Picker Tip will descend into both Tall and Short bins.

- (a) Adjustment scale is in Encoder Pulses. Five Pulses = One Inch.
- (b) Increase the number of pulses to go deeper into the bin. Too deep will cause the robot to attempt vending a bin.
- (c) Reduce the number of pulses to go less deep into the bin. Not deep enough will leave too much product in the bin.

Display			Programming Instructions
* = Next	21) U/D Travel Limit D = Back	# = Yes	a) Press the #=Yes key to enter Menu Option.
* = Next	Tall Bin Up/Down	212 #=Acc	b) Press "Up" or "Down" to make adjustments to Tall Travel Limits.
* = Next	Tall Bin Up/Down	210 #=Acc	c) Press #=Acc to accept the new value.
* = Next	Short Bin Up/Down	164 #=Acc	d) Press "Up" or "Down" to make adjustments to Short Travel Limits.
* = Next	Short Bin Up/Down	160 #=Acc	e) Press #=Acc to accept the new value.

U. VERIFY BINS –

Allows user to quickly step the Robot Arm through all programmed bin locations to verify accuracy. Reposition Robot Arm or accept programmed locations as they are and then move on to the next selection.

Display			Programming Instructions
* = Next	22) Verify All Bins D = Back	# = Yes	a) Press the #=Yes key to enter Menu Option.
A1 *=Cancel	Move the Robot #=Accept		b) Position Robot Arm more accurately and / or press #=Accept to accept programmed location. Robot Arm will move to the next programmed location each time # =Accept key is pressed until all locations have been verified.

V. MDB SETTINGS

Allows user to specify settings for currency system.

- *Force Vend - Customer cannot use the vendor for the purpose of changing bills. If a bill is inserted and the coin return button is pressed, it is ignored. A selection must be chosen. The only exception is when the selection is sold out.*
- *No Cheat - Bills are not accepted if there is not adequate change for a refund in the event of a failed vend.*
- *Change Bill - Similar to forced vend but focuses only on bills that have been accepted, whereas force vend is also concerned with coins.*
- *Hold Lost Credit - Funds that could not be returned to a customer during a vend are available for another transaction.*
- *Multi Vend - Change is not automatically returned after a transaction, but held for another transaction or until coin return is pressed.*
- *Lev 2 Coin Mech - When set to "N" (default), the coin mechanism will determine optimum change. If set to "Y", the VMC will determine what coins to give back as change, regardless of the capabilities of the coin mechanism. Power to the VMC must be cycled off and back on after changing this setting.*
- *Instant Reval - When set to "Y" (default), a stored value cashless device can receive revaluation credit as soon as coin or cash is inserted into the vendor. When option is set to "N", revaluation occurs when a major action is taken such as pressing the coin return. This option is only necessary for older cashless systems where the number of revaluations per credit device is limited.*

Display		Programming Instructions
23) MDB Settings		a) Press the #=Yes key to enter Menu Option.
* = Next	D = Back	
Force Vend *=Change	N #=Accept	b) Press *=Change to change setting and # to accept choice.
No Cheat *=Change	Y #=Accept	c) Press *=Change to change setting and # to accept choice.
Change Bill *=Change	N #=Accept	d) Press *=Change to change setting and # to accept choice.
Hld Lost Crdt *=Change	Y #=Accept	e) Press *=Change to change setting and # to accept choice.
Multi-Vend *=Change	N #=Accept	f) Press *=Change to change setting and # to accept choice.
Lev2 Coin Mech *=Change	N #=Accept	g) Press *=Change to change setting and # to accept choice.
Instant Reval *=Change	Y #=Accept	h) Press *=Change to change setting and # to accept choice.

W. Soft Drop –

Allows the picker tip to lower the product before it is released into the Delivery Bin. The release height may be adjusted and Soft Drop may be turned “ON” or turned “OFF”.

Display		Programming Instructions
* = Next	24) Soft Drop D = Back	# = Yes
Use Up / Down Keys		a) Press the #=Yes key to enter Menu Option.
*=Turn Off		#=Accept
Saved		b) Use Service Keypad up/down keys to adjust soft drop level and press #= Accept. c) Press * to turn function “OFF”.
*=Turn Off		#=Accept
		New Soft Drop release height is saved.

32. Instructions to Flash Update DIVI Firmware PRIOR to V119K

Necessary tools and components:

- **Micro SD Card – 1 to 2 GB.**

Note: DIVI program updates can be sent via e-mail and saved to a Micro SD Card. This may require the use of an SD adaptor and / or possibly a USB adaptor.

- Open the DIVI machine door and turn the VMC power “OFF”. The power switch is located on the left side of the Power Supply under the delivery bin.
- Open the inner door located to the left of the window opening.
- The VMC Board is located at the top of the opening and the Digital Display Board is located directly below the VMC. Unlatch the right side of the Display Board and flip it around so that the display may be viewed from the back of the door.
- The Microprocessor (daughter) Board is located on the upper right corner of the VMC Board. Remove the Micro SD card from its SD Adapter and carefully insert it into the metallic slot located on the upper right corner of the daughter board.
 - The Micro SD card should be inserted straight down into the slot.
 - The contacts on the Micro SD card must face away from you.
 - The lettering on the card will be facing you.
 - There should be an audible “click” when the card is seated.
 - If the card does not drop smoothly into the slot, remove and retry.

*****DO NOT FORCE THE MICRO SD CARD INTO THE SLOT****

BOOT LOADER UPGRADE: To be installed prior to major program revisions. (From Program Revision Prior to 119K)

Turn the Power Supply power switch "ON".

Use the asterisk "*" key to scroll through the contents of the Micro SD card. There may be more than one program version contained on the card. Use the "*" key to scroll to the latest or highest number version of the boot loader.

The boot loader version will be displayed in the "BOOTVxxx.bi2" format, where "xxx" is the numeric revision number. For example, BOOTV238.bi2.

Press the pound "#" key. The Display will read:

- *PROGRAMMING*
- *BootVxxx.bi2*

An LED status light on the right side of the board will start flashing rapidly. When the process is complete, the display will read:

- Update success.
- Remove card.....

Press down gently on the top of the card and let go. The card will slide up slightly in the sleeve. Leave the Micro SD card in the slot. The Display will read:

- BOOT UPDATE xxx
- Done!
- The Display will change to read:
 - *BOOT LOAD xxx*
 - *Out of Service*

PROGRAM REVISION UPGRADE: (From Program Revision Prior to 119K)

Gently, press down on the Micro SD card so that it locks into the slot. The Display will scroll between the options on the Micro SD Card menu:

1. Load Config.
2. Save Config.
3. Load Firmware
4. Save DEX Sales

Press “3” to load new firmware.

Use the asterisk “*” key to scroll through the contents of the Micro SD card. Scroll to the latest or highest number version.

The program version will be displayed in the “FC0xxxy.bi2” format, where “xxx” is the numeric revision number and “y” is the alphabetic revision suffix. For example, FC0124J.bi2.

Press the pound (#) key to enter the selection. The Display will read, “Programming”. An LED status light on the right side of the VMC Board will start flashing rapidly. When the process is complete, the display will read, “UPDATE SUCCESS. Remove card...”

To remove the Micro SD card, press down on the top of the card. It will slide up enough for you to lift the card straight up and out.

Notes -

- a) Power does NOT have to be turned “OFF” to remove the SD card.
- b) The vacuum may produce a clicking sound during this procedure. This is normal and is not a concern.
- c) A major firmware upgrade may require the Robot Arm to be re-calibrated. Please refer to the section, “Calibrating the Robot Arm” in your manual. Scroll to Service Menu Option “4) Create Selection”, Press “#” and follow the prompts to calibrate the Robot Arm.
- d) Your programming data will need to be re-entered after this upgrade. Go to Service Menu Option 4) Create Selection, Press “#” and follow the prompts to program your machine. Going forward, the data will be saved and automatically re-installed as part of the upgrade process.

You can save a copy of your bin configuration onto your Micro SD Card as a backup file or to use to program other machines. Insert the card into the slot on your board after programming your first machine.

- A. Press “2” to “Save Config”.
- B. Choose a name for your bin configuration and save the file onto your Micro SD card (see Fig. 12 in the next section). Remove the card from the daughter board.
- C. To upgrade additional machines install the Boot Loader and Program Upgrades per instructions. To install the bin configuration, insert the Micro SD card, Press “1” to “Load Config”. Use the * key to scroll through the configuration files then press # to install the bin configuration for your machine.
- D. Go to Menu 22) Verify Bins to confirm accuracy. Make adjustments if necessary.
Contact Fastcorp Tech Support at 888-441-3278 if you have any questions.

Instructions to Flash Update DIVI Firmware After Revision V119K2

33. The DIVI firmware after revision V119K2 provides many upgrades that have enhanced the functionality and versatility of the DIVI Vendor. More notable additions include the ability to:

- a) Load a machine configuration from a Micro SD card
- b) Save a machine configuration to a Micro SD card
- c) Load new Firmware from a Micro SD card
- d) Save DEX sales data to a Micro SD card

If the user selects “Load New Firmware”, the firmware will automatically save a copy of the existing programming configuration before starting the firmware upgrade. Once the firmware upgrade is complete, the new firmware will automatically look to see if a programming configuration had been saved and will restore that configuration into its operational memory.

If it is necessary to save a bin configuration or DEX data to a Micro SD card, the naming convention used is similar to that once used in cell phone technology for texting and saving phone numbers:

	1	2	3	4	5	6	7	8	9	0
International Standard		ABC	DEF	GHI	JKL	MNO	PQRS	TUV	WXYZ	

Fig. 12 Phone Dial Pad

To name a configuration, “BINS”:

- e) Press the number 2 twice = B
- f) Press the number 4 three times = I
- g) Press the number 6 twice = N
- h) Press the number 7 four times = S

If you make a mistake, use the * key to scroll backwards and clear an entry.

- Although DEX sales data remains untouched throughout the program upgrade process, the user should manually save a copy of DEX sales data to the Micro SD card before upgrading the firmware.
- **Instructions to Update Firmware after Revision V119K:**
- Necessary tools and components:
- **Micro SD Card – 1GB to 8GB.**
- Open the DIVI machine door.
- Open the inner door located to the left of the window opening on the inside of the door.
- The VMC Board is located at the top of the opening and the Digital Display Board is located directly below the VMC. Unlatch the right side of the Display Board and flip it around so that the display may be viewed from the back of the door.
- The Microprocessor (daughter) Board is located on the upper right corner of older VMC Boards. Newer versions incorporated all functions into the VMC board. Remove the Micro SD card from its SD adapter and carefully insert it into the metallic slot located on the upper right corner of the VMC board.

- Notes -
 2. The Micro SD card should be inserted straight down into the slot.
 3. The contacts on the Micro SD card should face away from you.
 4. The lettering on the card will be facing you.
 5. There should be an audible “click” when the card is seated.
 6. If the card does not drop smoothly into the slot, remove and retry.
***DO NOT FORCE THE MICRO SD CARD INTO THE SLOT**

34. **SAVE BIN CONFIGURATION AND DEX FILES: (Firmware after Revision V119K)**

The Display will scroll between the options on the Micro SD Card menu:

- A. Load Config.**
- B. Save Config.**
- C. Load Firmware**
- D. Save DEX Sales**

Enter “2” to save your current bin configuration. Name your bin configuration appropriately using the naming convention described in the previous section (see Fig. 12). Press “#” to save your bin configuration to your Micro SD card. Push down slightly on your Micro SD card and then let it go. It will pop up slightly in the socket.

We recommend that you also save your DEX data. Push down on the Micro SD card again while it is still in the slot and when the scrolling display again appears, enter “4” to save and name your DEX file(see Fig. 12).

35. **Major Program Upgrades** may require a Boot Loader Upgrade in addition to the Program Upgrade.

Note:

Reinstalling the Boot Loader will not have any effect on the Boot Loader or Program Upgrade.

BOOT LOADER UPGRADE: (Firmware after Revision V119K)

The MICRO SD Card should still be in the Daughter Board slot. Press down on the card as before.

The Display will scroll between the options on the Micro SD Card menu:

- a)Micro SD Ready...
 - (1) Load Config.
 - (2) Save Config.
 - (3) Load Firmware
 - (4) Save DEX Sales

Enter “3” to load new firmware.

Use the asterisk “*” key to scroll through the contents of the Micro SD card. There may be more than one program version contained on the card. Typically there will also be a boot loader program. Use the “*” key to scroll to the latest or highest number version of the boot loader.

The boot loader version will be displayed in the “BOOTVxxx.bi2” format, where “xxx” is the numeric revision number. For example, BOOTV238.bi2.

Press the pound “#” key. The Display will read:

- **PROGRAMMING**
- **BootVxxx.bi2**

A LED status light on the right side of the board will start flashing rapidly. When the process is complete, the display will read:

- **Update success.**
- **Remove card.....**

Press down gently on the top and let go. The card will slide up slightly in the sleeve. Leave the Micro SD card in the slot. The Display will read:

- **BOOT UPDATE xxx**
- **Done!**
- **The Display will change to read:**
 - **BOOT LOAD xxx**
 - **Out of Service**

PROGRAM REVISION UPGRADE: (Firmware after Revision V119K)

The MICRO SD Card should still be in the Daughter Board slot. Press down on the Micro SD card so that it locks into the slot. If The display will show **Micro SD ready:**

1. *Load Config.*
2. *Save Config.*
3. *Load Firmware*
4. *Save DEX Sales*

Enter “3” to load new firmware.

There may be more than one program version contained on the card. Use the “*” key to scroll to the latest or highest number version.

The program version will be displayed in the “FC0xxxy.bi2” format, where “xxx” is the numeric revision number and “y” is the alphabetic revision suffix. For example, FC0120F.bi2.

Press the pound (#) key to enter the selection. The Display will read, “**Programming**”. An LED status light on the right side of the VMC Board will start flashing rapidly. When the process is complete, the display will read, “**UPDATE SUCCESS. Remove card...**”

To remove the Micro SD card, press down on the top. It should slide up slightly allowing you to grasp it between your fingers. Lift the SD card straight up and out.

Notes -

- Power does NOT have to be turned OFF to remove the SD card.
- The vacuum may produce a clicking sound during this procedure. This is normal and is not a concern.
- A major firmware upgrade may require the Robot Arm to be re-calibrated. Please refer to the section, “Calibrating the Robot Arm” in your manual. Scroll to Service Menu Option “4) Create Selection”, Press “#” and follow the prompts to calibrate the Robot Arm.
- Your programming data should have been saved to your Micro SD card and automatically reinstalled with the program upgrade. Test vend selections to confirm accuracy. Go to Service Menu 22) Verify Bins to check accuracy and make adjustments if necessary.

If your bin configuration had not been saved, reinsert your Micro SD card into the Daughter Board slot.

- *Press1 to Load Config.*
- *Choose the name that you used to save your bin configuration.*
- *Test-vend selections to confirm accuracy. Go to Service Menu 22) Verify Bins to check accuracy and make adjustments if necessary.*

36. Robot Control Sequence / Order of Operations

Control of the Robot Arm and the Freezer proceed through a sequence of states during the course of the vend cycle and until the product is delivered. These states are detailed below:

A. Idle State:

The Robot Arm is at the delivery position with the freezer closed.

B. Vend Cycle Begins:

Money is inserted into the machine and a selection is made. A credit is established and Control issues a request to convert a selection number into a product location.

The Freezer Open Switch and Freezer Closed Switch circuits are inspected. If both circuits are active, an error is declared. Otherwise, Control issues a request to open the Freezer. A seven second timer is set and Control proceeds to the “Freezer Open” state.

C. Freezer Open:

Control waits for one of the following conditions to occur:

- The Freezer Open Switch is detected.
- The seven second timer expires and the Freezer Lid is still not open.
- A period of time has elapsed without “seeing” Freezer Encoders.

D. A Freezer Lid Lift Motor over-current is detected.

When the Freezer Open Switch has been detected, a sequence of destinations is generated for the Robot Arm. In order to avoid hitting a gusset or wall, the Robot Arm will need to move to an intermediate position inside the cabinet, and then proceed to a position directly over the requested bin. Control starts a timer, sets the Robot Arm in motion and advances to the “Retrieve Inside Cabinet” state.

E. Retrieve Inside Cabinet:

Control guides the Robot Arm to an intermediate position. The Z axis (Up/Down) Home Switch is monitored while the Robot Arm is moving. The Z (Up) Motor is engaged, as necessary, to pull the picker tip up and to maintain the Z Home Switch in an active state. Control waits for one of the following conditions to occur:

- The intermediate cabinet position is reached.
- The timer monitoring the Robot Arm expires.
- A Robot Arm over-current condition occurs.
- The Robot Arm Angular Sensors report inaccurate data.

When the intermediate cabinet position has been reached, Control advances to the “Retrieve Product” state.

F. Retrieve Product:

“Retrieve Product” is similar to the “Retrieve Inside Cabinet” state. Control directs the Robot Arm to reach a destination directly above the requested bin. When the destination has been reached, Control will set a 5 second timer while the Robot Arm pauses. The “pause state” will allow the Robot Arm to stabilize before the picker tip descends into a bin.

G. Pause

After the Robot Arm stabilizes, power to the Vacuum Pump is slowly ramped up until it is at the ideal level for product detection. A timer is set and the Z Motor is engaged to descend into the bin. Control proceeds to the Z (Down) state.

H. Z Down

We wait for one of the following to occur:

- *An increase in current through the Vacuum Pump circuit indicates that product has been detected.*
- *Z Down timer expires.*
- *Z Encoder Pulses are not detected or the signal is lost.*
- *The Z Home Switch never goes inactive (open circuit).*
- *The number of encoder pulses exceeds the bin depth.*

If product contact is made, the Z Down Motor is halted and (following another pause state to confirm product contact) a timer is set, a “slowdown point” is calculated for the upward travel, a current value is calculated which represents a dropped product and control proceeds to the Z Up state after engaging the Z motor in the UP direction.

A. Z Up

(1) The Vacuum Pump remains ON as it ascends with the product out of the bin. Control waits for one of the following:

- (a) The Z Home Switch is detected (active).*
- (b) Z Up timer expires.*
- (c) Z Encoder Pulses are not detected or the signal is lost.*
- (d) Current flow indicates a dropped product.*

(2) When the Z Home Switch is detected, another sequence of destinations is generated for the Robot Arm. To avoid hitting a gusset or a wall, the Robot Arm will move to an intermediate position inside the cabinet and then proceed to the delivery position. Control starts a timer, sets the Robot Arm in motion and advances to the cabinet intermediate position. Control advances to “Deliver Inside Cabinet” state.

B. Deliver Inside Cabinet

The Vacuum Pump remains ON as long as a problem is not detected. The Z axis (Up/Down) Home Switch is monitored while Control guides the Robot Arm to the cabinet intermediate position. The Z- (Up) Motor is engaged, as necessary, to pull the picker tip up and to maintain the Z Home Switch in an active state. Control waits for one of the following conditions to occur:

- *The intermediate cabinet position has been reached.*
- *The timer monitoring the Robot Arm expires.*
- *A Robot Arm over-current condition occurs.*
- *The Robot Arm Angular Sensors report inaccurate data.*
- *Current monitoring indicates that the product dropped.*

When the intermediate cabinet position has been reached, Control advances to the “Deliver to Home” state.

C. Deliver to Home

Deliver to Home is similar to the “Deliver Inside Cabinet” state. If the Robot Arm reaches the delivery position without issue, the vend cycle will be considered successful.

1. *If the Soft Drop feature had been enabled, Control will direct the Z Motor to descend the appropriate number of encoder pulses before turning OFF the Vacuum Pump to release product into the Delivery Bin. After product has been released, the Z Motor will reel up the picker tip until the Z Home Switch is active.*
2. *If the Line Mode feature had been enabled, Control will turn OFF the Vacuum Pump to release product into the Delivery Bin and set a 20 second timer. If a new vend request arrives, the vend cycle will begin anew. If no new vend request arrives, then Line Mode will time out after 20 seconds.*

Control will direct the freezer to close, set a timer and then Control will proceed to the “Freezer Close” state.

D. Freezer Close

We wait for one of the following to occur:

- (a) *The Freezer Closed Switch has been detected.*
- (b) *The Freezer Open Switch is detected.*
- (c) *The timer expires and the freezer is still not closed.*
- (d) *A period of time has elapsed without “seeing” freezer encoders.*
- (e) *A Freezer Lid Lift Motor over-current is detected.*

When the Freezer Closed Switch has been detected, Control will advance to a “Clean-up” state before returning to the “Idle” state to await another vend request.

E. Cleanup

The “Clean-Up” state issues the “Vend Success” or “Vend Failure” signal to the Executive portion of the DIVI firmware. Control resets all parameters to prepare for the next vend request. Motors and switches are inspected. If the Vacuum Pump has returned to the garage, if the Z Home Switch is active, if the Robot Arm is at the delivery point and if no errors have been reported then Control will return to the “Idle” state.

37. APPENDIX

DIVI Lid Lift Mechanism Replacement and Installation Instructions

Necessary Tools and Accessory Items:

- ¼” wrench;**
- 3/8” wrench;**
- 5/16” wrench;**
- cutting pliers;**
- (8) Cable Ties – 7-½”**

38. The Fastcorp DIVI Lid Lift Mechanism can be removed and replaced in approximately 30 to 45 minutes.

- A. Locate the power switch on the left side of the Power Supply under the delivery bin and turn it “OFF” to remove power to the VMC Board and the Freezer Lid Lift Mechanism.
- B. Reach down behind the freezer to unplug the 2 pin connector for the circulation fan.
- C. Reach behind the freezer (right rear corner) to unplug the 2 pin thermistor connector. The harness will be labeled, “freezer”. Be careful of sharp edges inside the cabinet.
- D. Remove the cover from the Freezer Closed Switch Assembly (right front corner of Freezer). Make note of how the harness is plugged into the switch (common and normally open) and then unplug the switch.
- E. Note how the Freezer Lid Lift Harness is routed and where the cable ties are positioned. Mark each location on the cabinet and the harness. Follow the harness to the VMC Board and disconnect the connector at J3.
- F. Carefully cut and remove the cable ties that hold the harness in place.
- G. Manually open the Freezer Lid to access and remove the two (2) Freezer Lid Lift Mechanism retaining screws using a 3/8” wrench. These screws will be used over again to install the new mechanism.
- H. If machine is equipped with fuse block for the lid lift, remove wires identified for the lid lift in the fuse identification table, by using a 3-4mm flat screw driver and insert in the fuse block wire port to release the wire, if this is not available, you can cut and wire nut the wires to the new harness.

- I. Remove the Lid Lift Mechanism and carefully pull the harness through the cabinet reinforcement bracket.
- J. Reverse the above instructions to install the new Freezer Lid Lift Mechanism. Take care not to damage the wiring harness when threading it through the cabinet reinforcement bracket.
- K. Adjust the lift arm so that the Lift Pin on the right side of the Freezer Lid will drop into the fork on the top of the Lift Arm. You may have to raise the lift arm slightly. The Lid Lift Mechanism is adjustable front and back.
- L. There is an adjustment at the bottom of the Lift Arm which determines how far the Freezer Lid will open before the Freezer Lid "Open" Switch is activated. Manually open the Freezer Lid. Tilt the top of the lift arm towards the back of the machine. The bottom of the arm will pivot outwards. You will need a ¼" wrench or nut driver to loosen the (2) screws. Raise the actuator plate to allow the "Open" Switch to activate sooner.

39. DIVI Robot Arm Installation Instructions

Necessary Tools and Accessory Items:

- **Phillips screwdriver, #2; 5/16" wrench; cutting pliers;**
- **(5) Cable Ties – 7-½"**

1. *Locate the power switch on the Power Supply under the delivery bin and turn it OFF to remove power from the VMC Board and Robot Arm.*
2. *Grab the hose at its access point to the robot arm and press the up button, this will retract the hose until free from rollers, pull hose out from robot and set aside.*
3. *Open the wire channel that contains the ribbon cable and disconnect the connectors from the VMC Board (J6 and J7). Make note of the connector orientation on the VMC. The Robot Arm Harnesses are routed through (2) black plastic wire channels located on the top of the right and rear cabinet walls. To open the wire channels, begin at the channel end closest to the Robot Arm and use your thumb to push up on the bottom of the channel while also pulling out on the top of the channel. The channels should unlatch on top while hinging on the bottom. Remove the harnessing from the wire channels.*
4. *Unplug the twelve pin connector located at the back of the robot arm (right side).*
5. *Remove the two screws securing the metal cover. Pull it aside to expose the mounting bracket, note that this cover will remain attached to the robot by the harnessing and be careful not to damage the wires.*
6. *The mounting shaft of the Robot Arm is clamped into a mount located on the back cabinet wall. The mounting shaft is held in place by (4) screws. Use either a 5/16" (8mm) socket wrench to loosen the (4) screws. Do not remove the (4) screws. Use one hand to support the Robot Arm while pulling out on the top of the hinged Robot Arm Clamp. When the clamp has been pulled out, the Robot Arm Shaft will drop down and out the bottom of the mount. The Robot Arm may now be removed from the machine.*

7. *Remove the replacement Robot Arm from the packaging and carefully unspool the harness. The Robot Arm Mounting Shaft is pointed on one side and has a horizontal “notch” on the other. The pointed side of the mounting shaft should face the rear cabinet wall as the shaft is installed back into the mount. As you slide the shaft up into the mount, you should hear an audible “click” as the “notch” slides past the clamp on the bracket. Support the Robot Arm until the (4) retaining screws are tight.*
8. *Reinstall the ribbon cables and connect the twelve pin connector and secure the robot arm cover.*
9. *Plug the (2) connectors back into the VMC Board. It is critical to ensure that the orientation of these connectors is properly placed since the wire position is essential. Take care not to bend any pins as you seat the connectors. Replace the cable ties so that the Robot Arm Harness is positioned next to the Lid Lift Harness as it was before. The Robot Arm Harness must be positioned clear of the inner door and outer door as the doors are opened and closed. Take care that the harnesses are not pinched by either door.*
10. *Review your work. Make sure that the Robot Arm fasteners are tight. Check all connections. Confirm that the Robot Arm moves freely without binding. Confirm that all wires and harnesses are positioned correctly and no wires are being pinched.*
11. *Turn on the machine using the Power Switch on the left side of the Power Supply below the Delivery Bin. Position the Display Board so that it may be viewed from the back of the door. Press the “VAC” button to unlock the keypad.*
12. *The new [Robot Arm must be calibrated](#) to the machine. Go to Service Menu Option 4) Create Selection. Press and hold the Reset button. The Display will first read, “THIS FORCES RE-SETUP” and then, “Arm Uncalibrated”. Release the Reset button. **If you continue to hold the Reset button you will erase all product selections and their freezer locations.***

Press the pound (#) key to continue. (See Fig. 9A and 9B) The Display will instruct you to “Put Arm at Left Wall”. Fold the robot arm into an L shape so that the arm is against the back cabinet wall and the left side cabinet wall. Press the pound (#) key to accept. The Display will instruct you to “Set Arm at Delivery”. Move the arm so it is straight out from the back wall with the picker tip in the front center position. Press the pound (#) key to accept.

At this point the calibration and installation process is complete. Your selections should still be programmed correctly. We recommend that you try a few test vendes to verify the operation and price settings.

40. Illustrations

DIVI Vending Machine

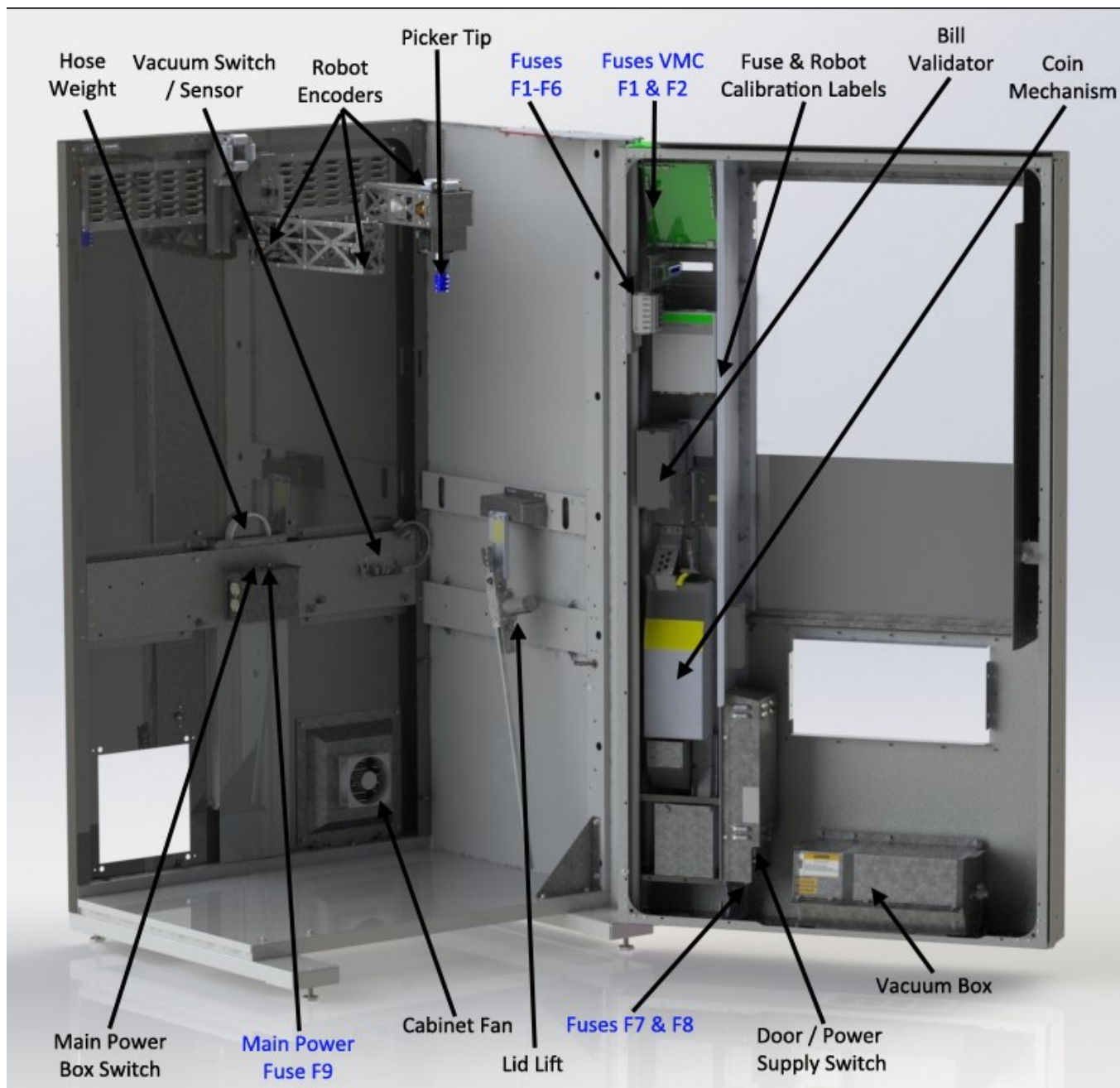

DIVI Vending Machine

110v Fuse Table.

FUSE TABLE / TABLEAU FUSIBLE	
ON CONTROL BOARD/SUR LE TABLEAU DE CONTRÔLE VMC F1 (5A Mini / ATM / APM) VMC F2 (7.5A Mini / ATM / APM)	
ON FUSE BLOCK/SUR BLOC FUSIBLE	
F1 - Shoulder Motor (0.8A TD) ● Épaule Moteur	F6 - Vacuum Motor (5A TD) En Haut / En Bas Moteur
F2 - Elbow Motor (0.8A TD) ● Coude Moteur	ON DOOR POWER SUPPLY BOX SUR LA BOÎTE D'ALIMENTATION DE LA PORTE
F3 - Fans (5A TD) Les Fans	F7 - VMC Fuse (10A TD)
F4 - Lid Lift Motor (5A TD) Couvercle Du Moteur De Levage	F8 - DC Lighting Fuse (3A TD) D'Eclairage Fuse
F5 - Up/Down Motor (2A TD) ● Couvercle Du Moteur De Levage	ON REAR POWER BOX SUR BOÎTE DE PUISSANCE ARRIÈRE
	F9 - Main Power Fuse (12A TD) D'alimentation Principale
5mm x 20mm for Fuses F1 - F9	
FA = Fast Acting/Action Rapide TD = Time Delay/Temporisation	
<small>©Clarion Safety Systems, LLC clarionsafety.com xxxxx Reorder No. 9000788-DIVI Rev 1</small>	

220v Fuse Table

FUSE TABLE / TABLEAU FUSIBLE	
ON CONTROL BOARD/SUR LE TABLEAU DE CONTRÔLE VMC F1 (5A Mini / ATM / APM) VMC F2 (7.5A Mini / ATM / APM)	
ON FUSE BLOCK/SUR BLOC FUSIBLE	
F1 - Shoulder Motor (0.8A TD) ● Épaule Moteur	F6 - Vacuum Motor (5A TD) En Haut / En Bas Moteur
F2 - Elbow Motor (0.8A TD) ● Coude Moteur	ON DOOR POWER SUPPLY BOX SUR LA BOÎTE D'ALIMENTATION DE LA PORTE
F3 - Fans (5A TD) Les Fans	F7 - VMC Fuse (10A TD)
F4 - Lid Lift Motor (5A TD) Couvercle Du Moteur De Levage	F8 - DC Lighting Fuse (3A TD) D'Eclairage Fuse
F5 - Up/Down Motor (2A TD) ● Couvercle Du Moteur De Levage	ON REAR POWER BOX SUR BOÎTE DE PUISSANCE ARRIÈRE
	F9 - Main Power Fuse (8A TD) D'alimentation Principale
5mm x 20mm for Fuses F1 - F9	
FA = Fast Acting/Action Rapide TD = Time Delay/Temporisation	
<small>©Clarion Safety Systems, LLC clarionsafety.com xxxxx Reorder No. 9000883-DIVI Rev 1</small>	

220V Fuse table w/ circuit breakers

FUSE TABLE / TABLEAU FUSIBLE	
ON CONTROL BOARD/SUR LE TABLEAU DE CONTRÔLE VMC F1 (5A Mini / ATM / APM) VMC F2 (7.5A Mini / ATM / APM)	
ON FUSE BLOCK/SUR BLOC FUSIBLE	
F1 - Shoulder Motor (0.8A TD) ● Épaule Moteur	F6 - Vacuum Motor (5A TD) En Haut / En Bas Moteur
F2 - Elbow Motor (0.8A TD) ● Coude Moteur	ON DOOR POWER SUPPLY BOX SUR LA BOÎTE D'ALIMENTATION DE LA PORTE
F3 - Fans (5A TD) Les Fans	F7 - VMC Fuse (10A TD)
F4 - Lid Lift Motor (5A TD) Couvercle Du Moteur De Levage	F8 - DC Lighting Fuse (3A TD) D'Eclairage Fuse
F5 - Up/Down Motor (2A TD) ● Couvercle Du Moteur De Levage	ON REAR POWER BOX SUR BOÎTE DE PUISSANCE ARRIÈRE
	Auto resetting circuit breakers 5A Freezer, 7A controls & vac / Réinitialisation automatique des disjoncteurs 5A Congélateur, 7A contrôles et vac
5mm x 20mm for Fuses F1 - F9	
FA = Fast Acting/Action Rapide TD = Time Delay/Temporisation	
<small>©Clarion Safety Systems, LLC clarionsafety.com xxxxx Reorder No</small>	

DIVI Vending Machine (parts hidden for clearer view)

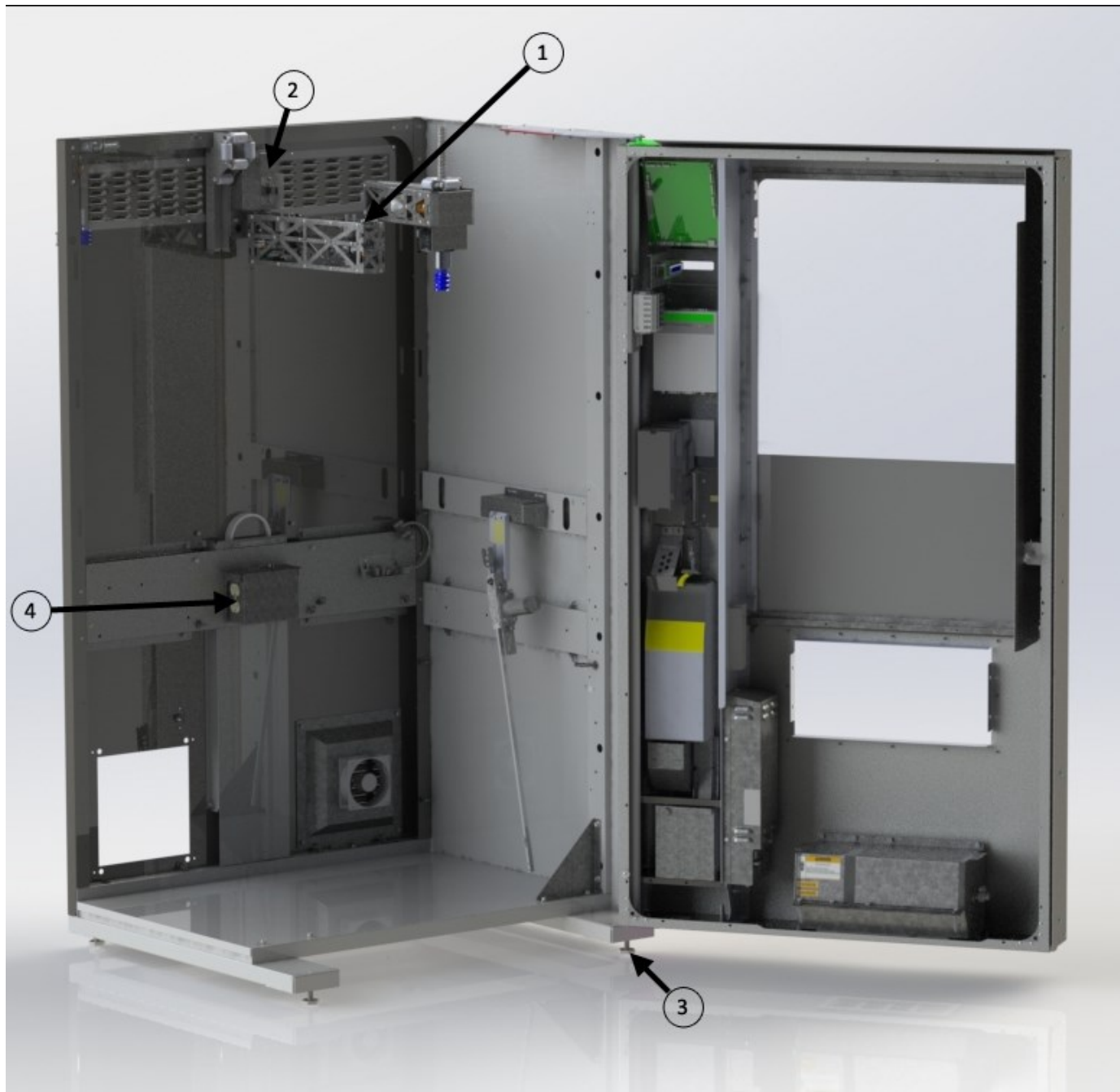

DIVI Vending Machine		
1	F003-A01460	Robot Arm Assembly
2	F003-A03951	Robot Mount Assembly
3	7000007	Leveling Foot
4	1200013 (115v) 1200063 (220v)	Rear Main Power Box Assembly

Nut Bracket Assembly, T-Handle Lock

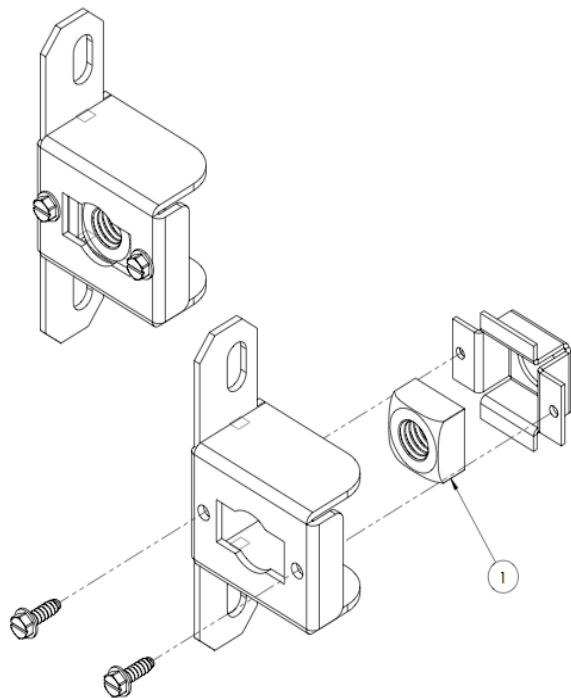

1100017 - Nut Bracket Assembly		
1	6100007	Nut Square ½-13

1.

Power Box – Cabinet

Model FS-01 - 115 VAC

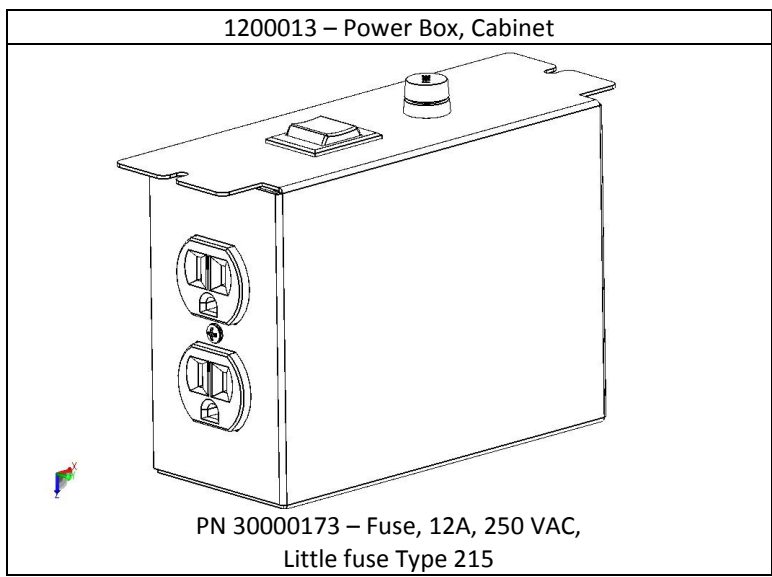

Model FS-02 - 230 VAC

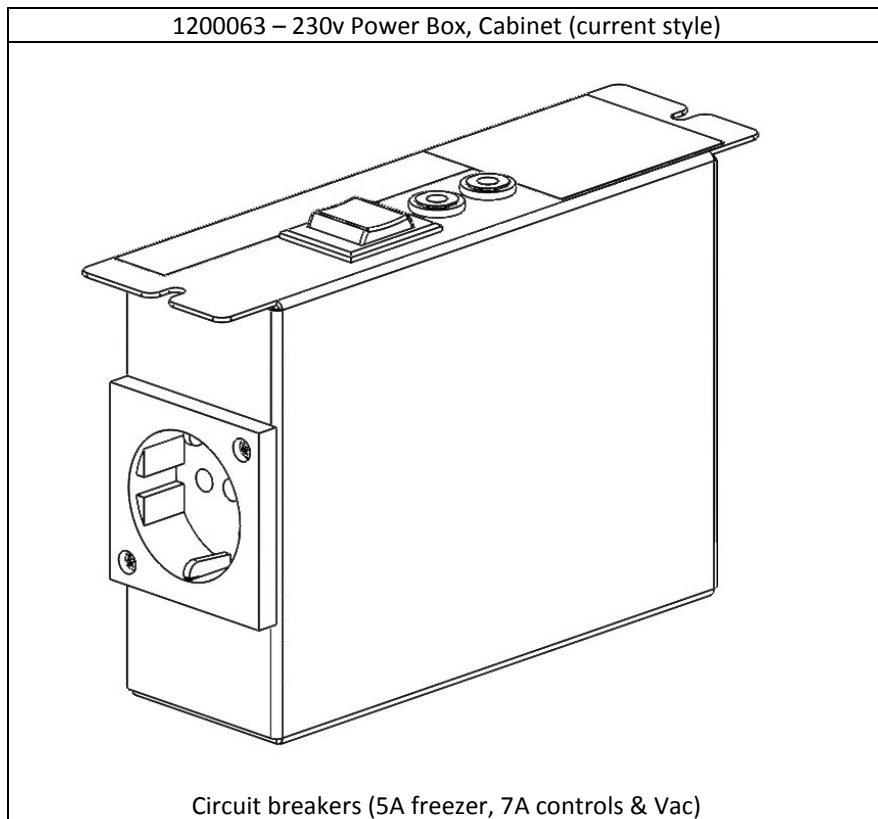
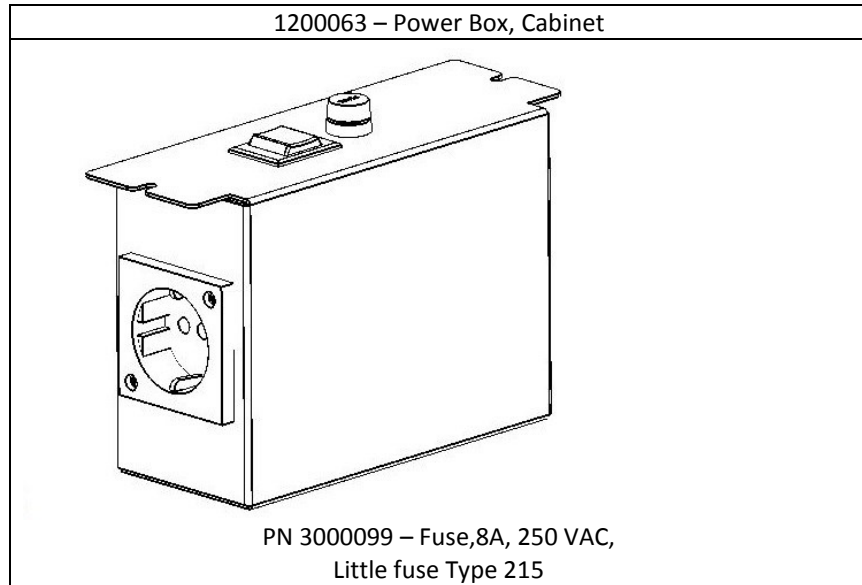

Power Supply Assembly,

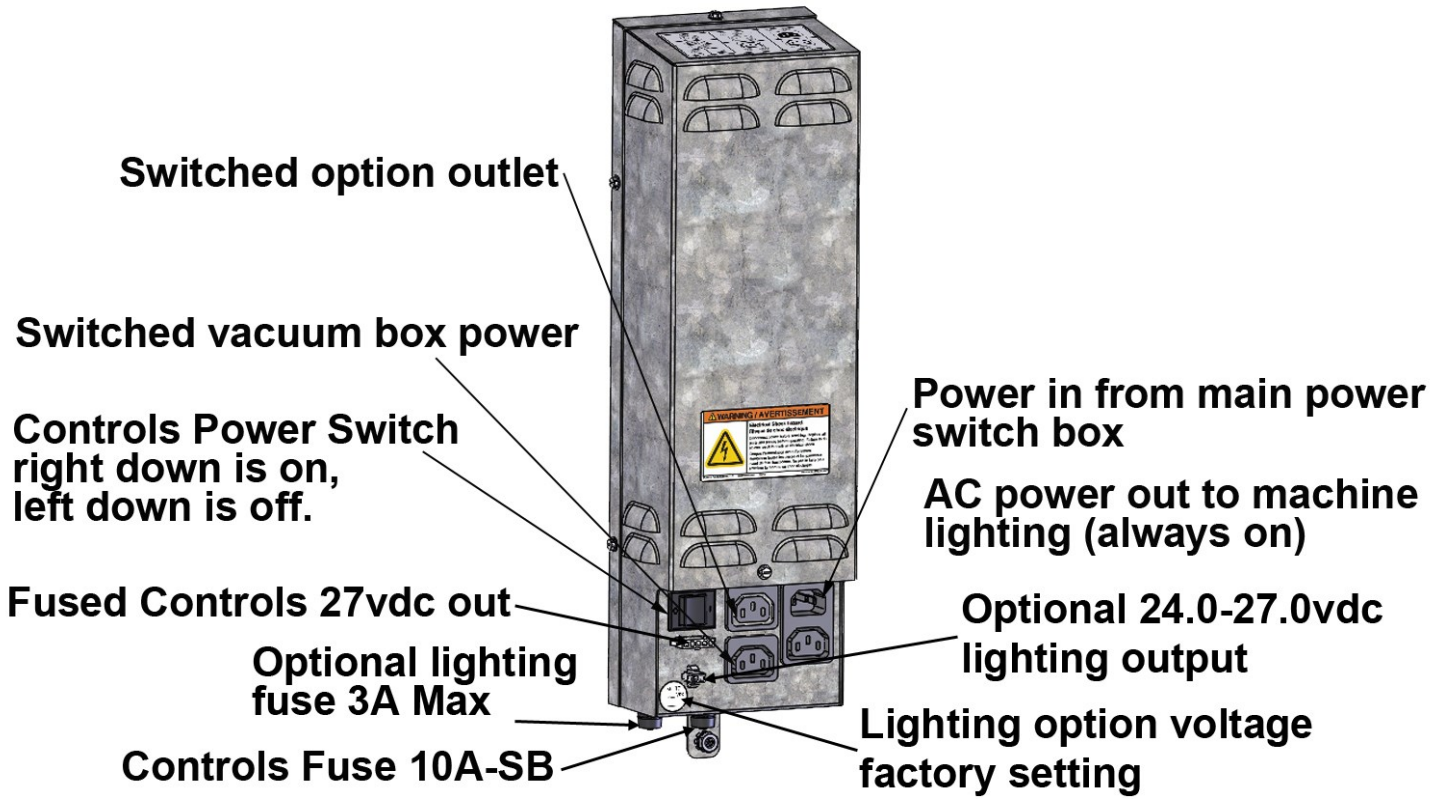

Power supplies with lighting option come factory set at 24.0v unless noted on voltage setting label on bottom left. If no label is present, voltage must be measured or it should be assumed to be 27VDC.

F003-A05383 for 27VDC power supply

F003-A07083 for lighting option output power supply (see F003-A07045 for lighting adapter harness)

Display Assembly

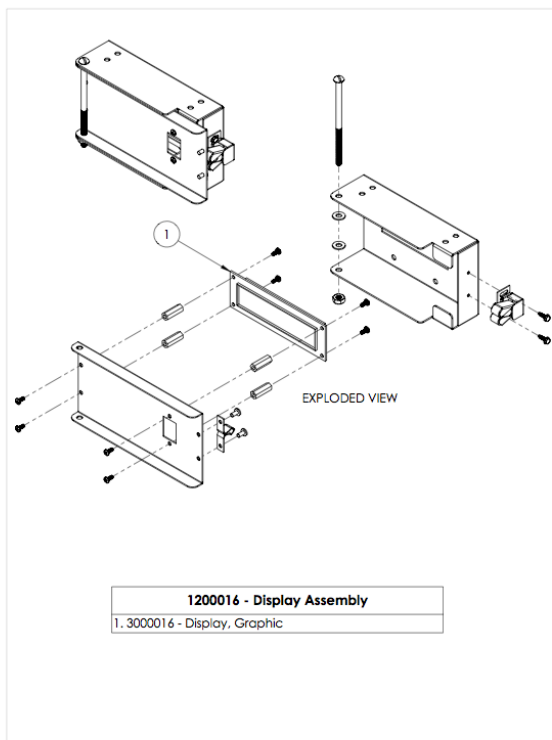

Freezer Lid Closed Switch

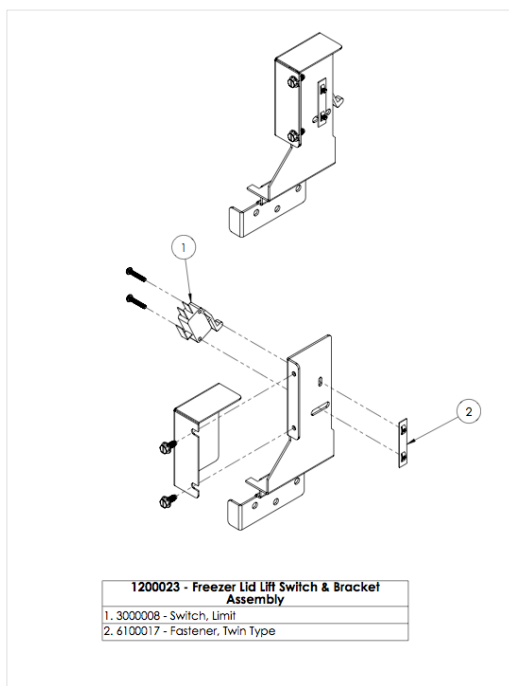

Vacuum Assembly

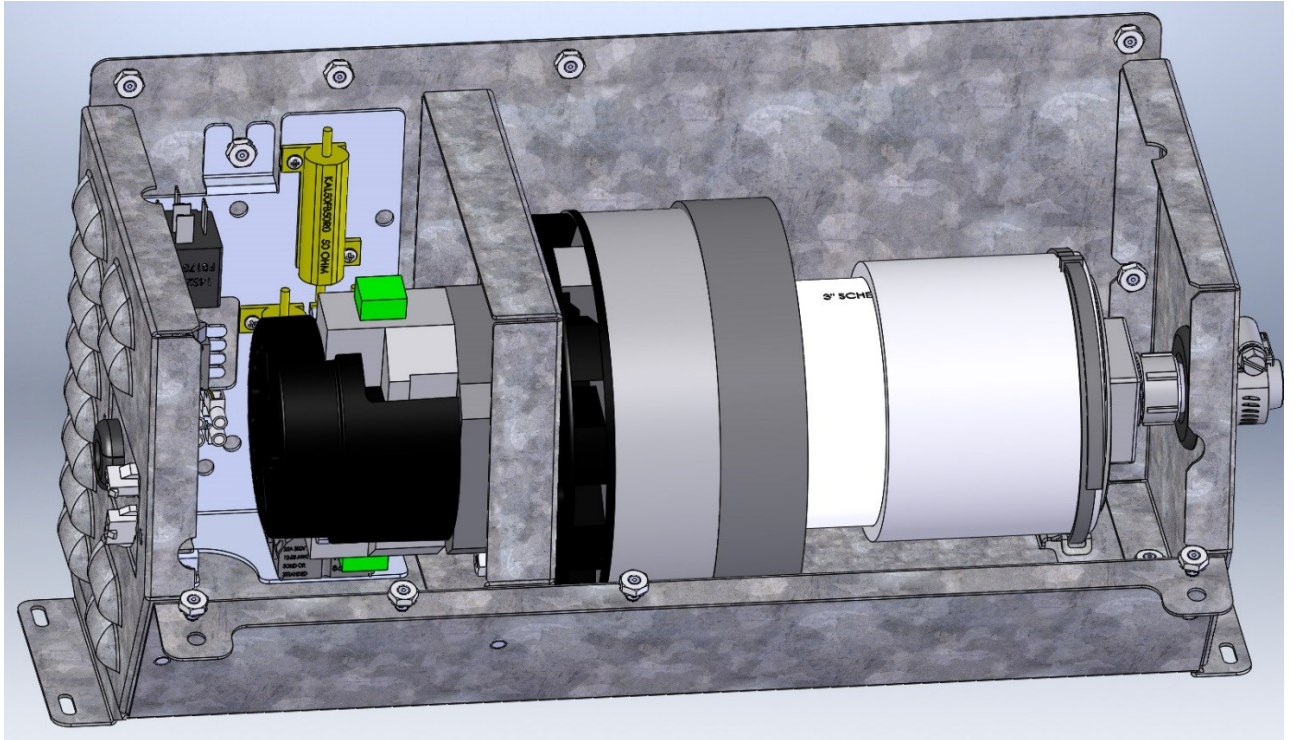

F003-A05431 - Vacuum Box Assembly (110v and 220v versions)

Freezer Lid Lift Assembly

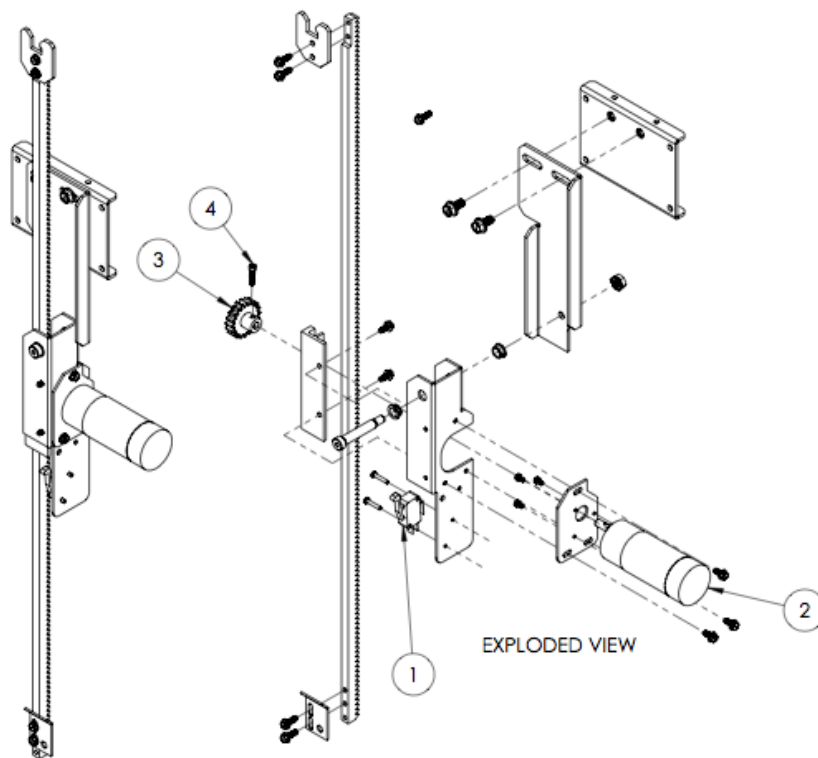

1100124 - Freezer Lid Lift Assembly		
1	49500566	Switch, Limit
2	80450155001	Motor
3	49500406	Gear, Sprocket
4	48909121	6-32x5/8" Screw

Freezer Assembly

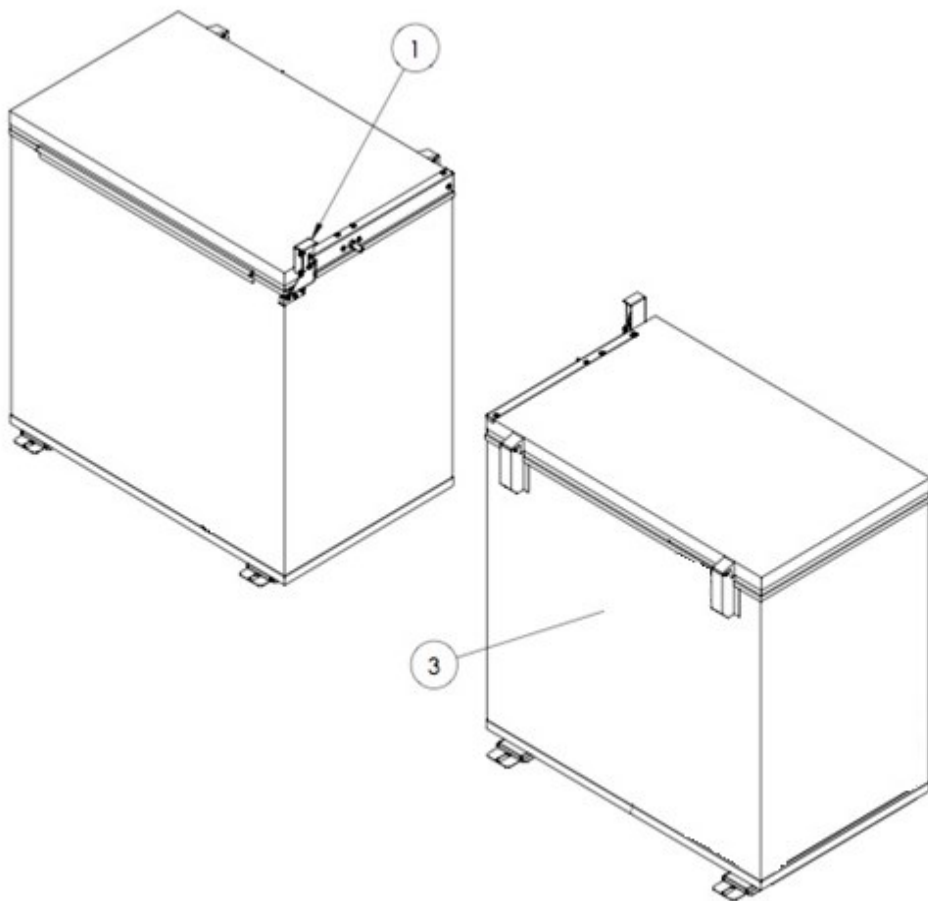

Freezer Assembly		
1	49500566	Freezer Lid Lift Switch
2	80492557001	Thermistor (not Shown)
3	CALL	Freezer

Wiring Diagram (single main power box fuse)

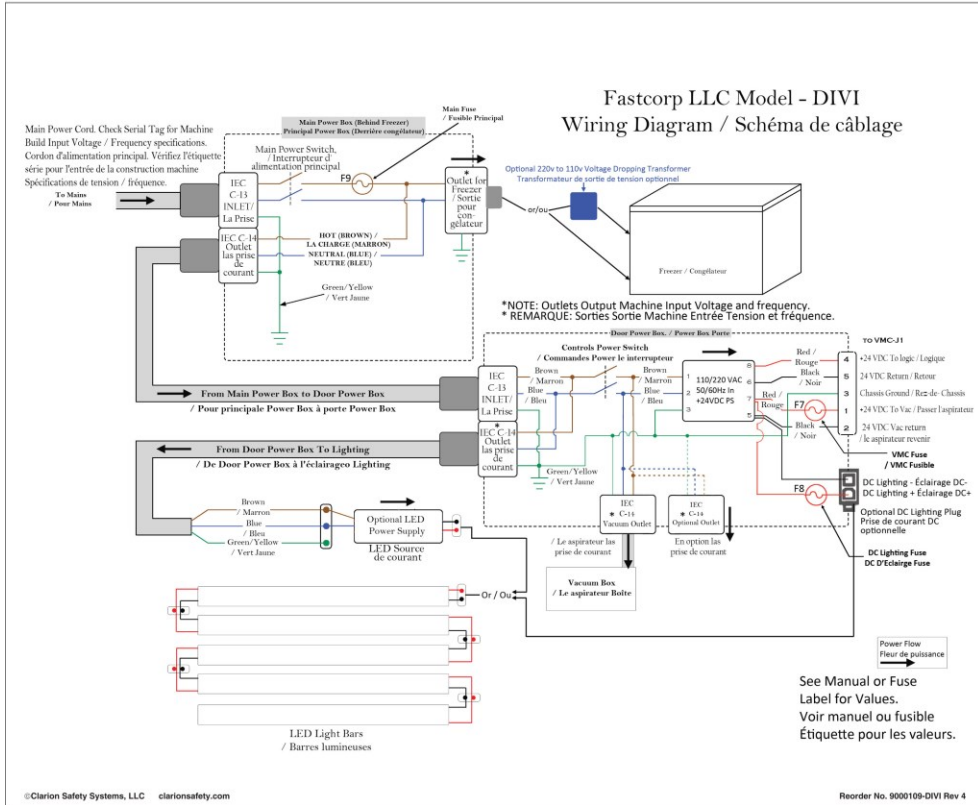

(with 2 circuit breakers)

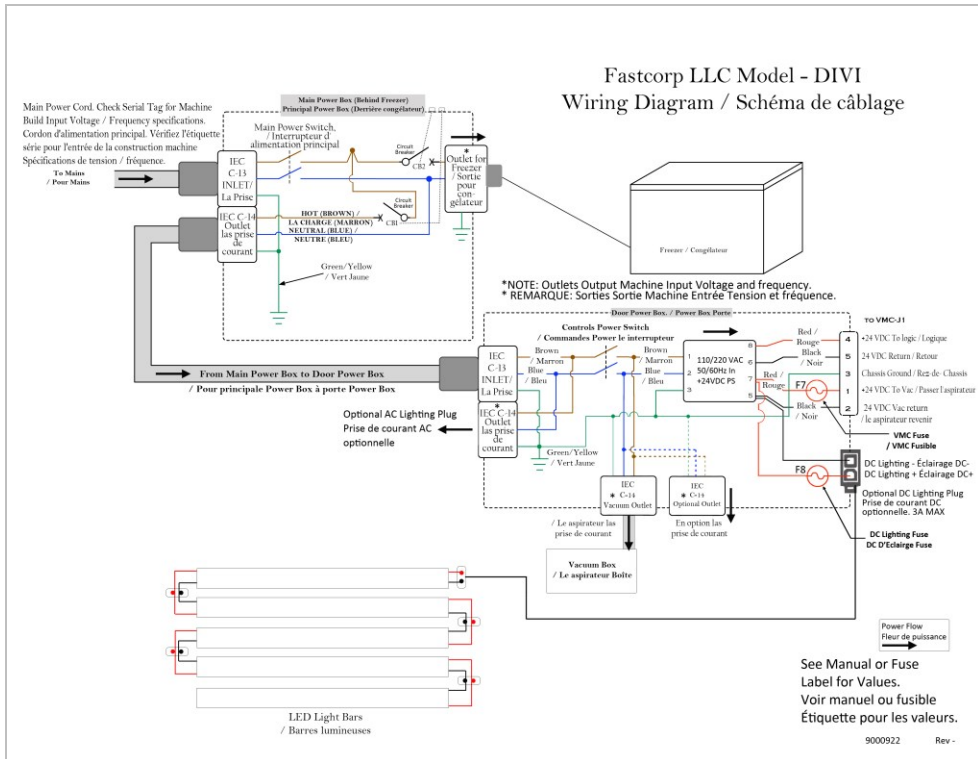

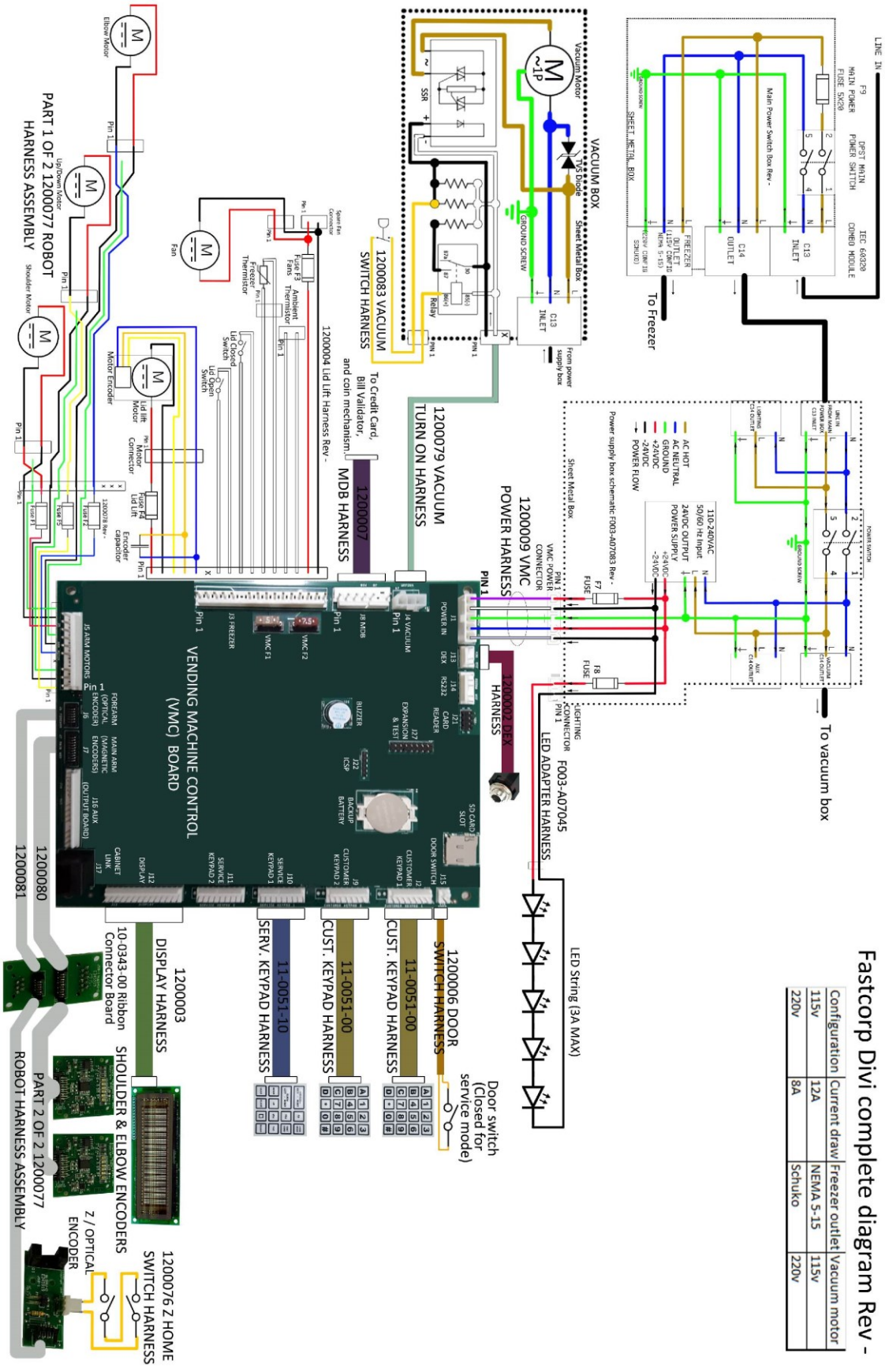

Fastcorp Divi complete diagram Rev -

Configuration	Current draw	Freezer outlet	Vacuum motor
115v	12A	NEMA 5-15	115v
220v	8A	Schuko	220v

VMC Connector layout

